



ITT

GPrimeLine

Commercial Water

Goulds Pumps

Marlow Series Prime Line[®]

Self-Priming Centrifugal Pumps

TECHNICAL DATA

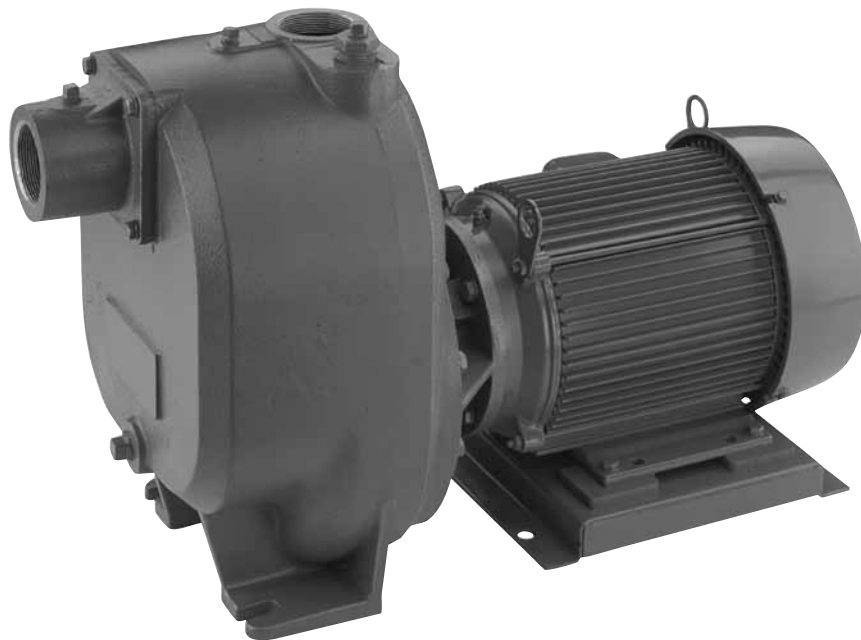

Engineered for life

Goulds Pumps

Commercial Water

Prime Line® A Full Range of Product Features

Rugged Construction: Cast iron construction in close coupled and frame mounted design.

Superior Priming: High suction inlet and internal suction check valve keeps more liquid in the casing for faster priming and repriming.

Diffuser Priming: The patented diffuser design allows impeller trim, reduces internal wear and eliminates radial loads.

High Efficiency: Enclosed, trimable impellers provide efficiencies from 60-75% for low energy costs.

Dimensional Interchangeability: Four pump groups allow performance to be changed with replaceable impellers and diffusers.

NOTE:
The various versions of the Prime Line are identified by product code numbers as explained to the right. Note that not all combinations of impeller and motor are possible.

Prime Line® Product Line Numbering System

Example Product Code

M2P1A21B2A0BC E

Epoxy Coated

CE label energy efficient

Optional Base (close-coupled)

Mechanical Seals

| Code | Rotary | Stationary | Elastomers |
|------|---------|------------|------------|
| 0 | Carbon | Ceramic | BUNA N |
| 1 | Carbon | Ceramic | Viton |
| 2 | Sil Car | Sil Car | Viton |
| 3 | Sil Car | Sil Car | EPR |

Impeller Options

| | 2P1 | 2P2 | 2P3 | 2P4 | 3P1 | 3P2 | 3P3 | 3P4 | 4P1 | 4P2 | 4E1 | 6E1 | 6E2 |
|---|------|------|------|------|------|------|------|------|-------|------|------|------|------|
| A | 6.88 | 4.88 | 5.69 | 6.88 | 8.75 | 5.88 | 8.06 | 7 | 10.63 | 9 | 12 | 11.5 | 12.5 |
| B | 6.5 | 4.63 | 5.44 | 6.63 | 8.5 | 5.5 | 7.69 | 6.75 | 10.38 | 8.75 | 11.5 | 11 | 12 |
| C | 6.13 | 4.38 | 5.19 | 6.38 | 8.25 | 5.13 | 7.31 | 6.5 | 10.13 | 8.5 | 11 | 10.5 | 11.5 |
| D | - | 4.13 | 4.94 | 6.13 | 8 | 4.75 | 6.94 | 6.25 | 9.88 | 8.25 | 10.5 | 10 | 11 |
| E | - | - | - | 5.75 | 7.75 | - | - | 6 | - | - | 10 | 9.5 | - |

Driver*

1 = 1 PH, ODP 6 = 575 V, TEFC
 2 = 3 PH, ODP 7 = 3 PH, Exp. Proof
 3 = 575 V, ODP 8 = 575 V, Exp. Proof
 5 = 3 PH, TEFC 9 = 1 PH, TEFC

Horsepower Rating*

A = 1½ HP D = 5 HP G = 15 HP K = 30 HP
 B = 2 HP E = 7½ HP H = 20 HP M = 40 HP
 C = 3 HP F = 10 HP J = 25 HP N = 50 HP

Driver: Hertz/RPM*

1 = 60 Hz, 3500 RPM 4 = 50 Hz, 2850 RPM
 2 = 60 Hz, 1750 RPM 5 = 50 Hz, 1450 RPM
 3 = 60 Hz, 1150 RPM

Shaft Sleeve

0 = No Sleeve (E-Series only)
 2 = 316 Stainless Steel

Impeller Material **

A = Iron
 S = Stainless Steel (4E1, 6E1)

Pump Size

2P1 = 2 x 2-6⅞ 3P2 = 3 x 3-5⅞ **Frame Mounted only:**
 2P2 = 2 x 2-4⅞ 3P3 = 3 x 3-8⅞
 2P3 = 2 x 2-5⅞ 3P4 = 3 x 3-7 4E1 = 4 x 4-12
 2P4 = 2 x 2-6 4P1 = 4 x 4-10⅞ 6E1 = 6 x 6-11½
 3P1 = 3 x 3-8¾ 4P2 = 4 x 4-9 6E2 = 6 x 6-12½

Marlow Series

Not used for frame mounted units, use FRM.
 FRS for frame mount with 316SS shaft.

* Substitute "FRM" for frame mounted with carbon steel shaft or "FRS" for frame mounted with 316SS shaft (316SS shaft available on frame mounted only).

** Recommended use of "FRS" frame with stainless steel impeller.

Prime Line® Performance Coverage (60 Hz) 2P – 4P

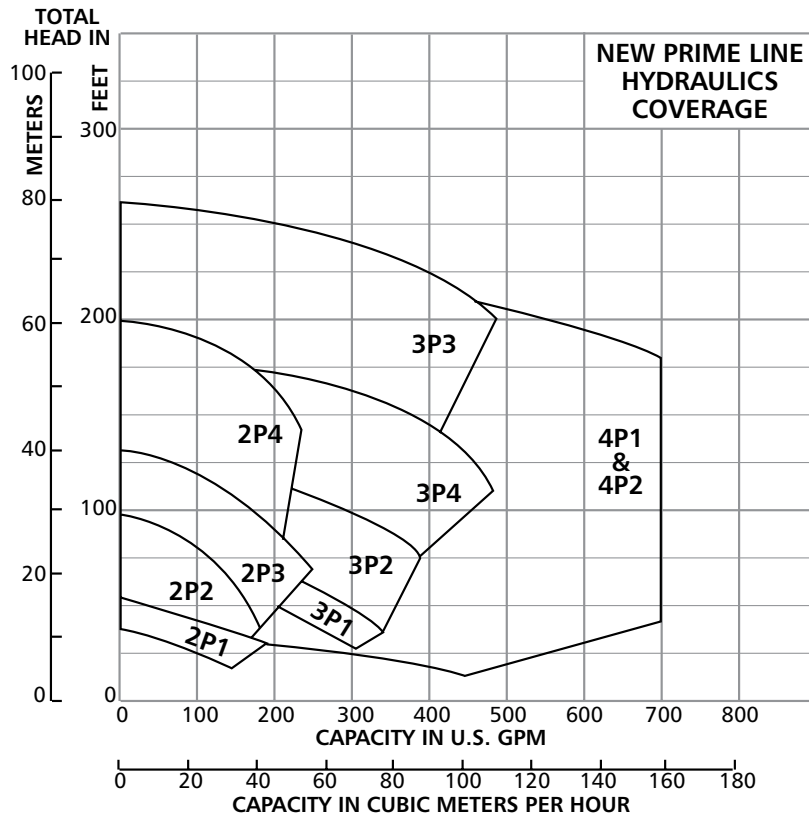

Prime Line® Key Features

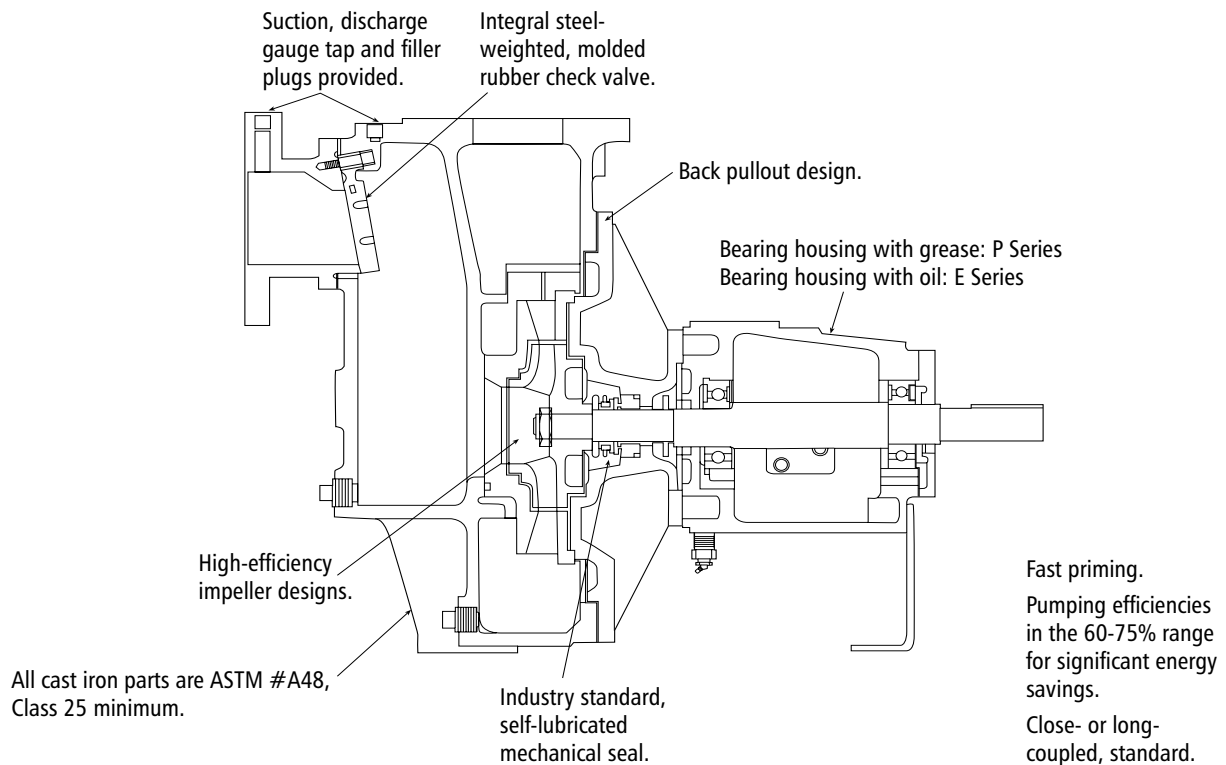

Goulds Pumps

Commercial Water

Prime Line® 2P – 4P Close-Coupled Pumps — Materials of Construction

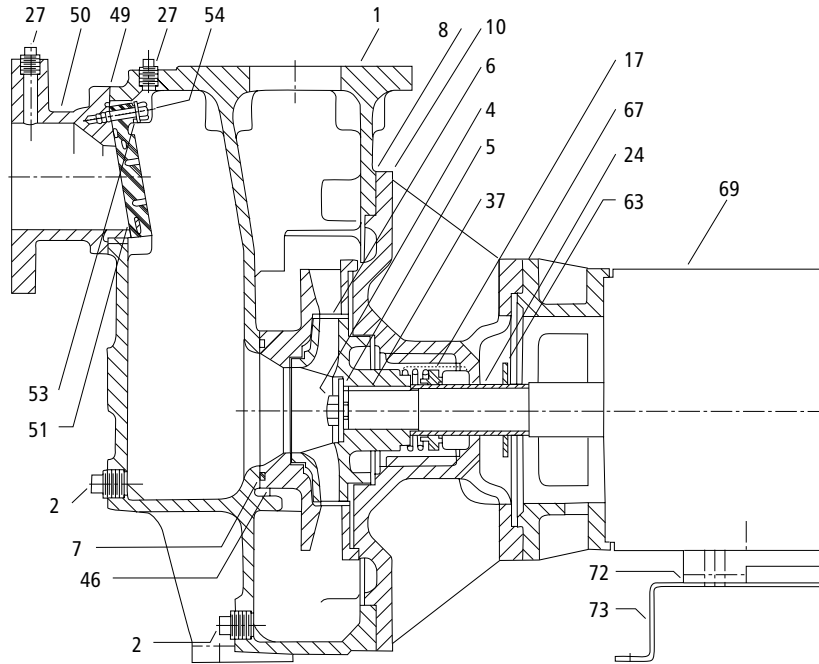

| Item No. | Description | Materials |
|----------|------------------------|-----------------|
| 1 | Casing | Cast Iron |
| 2 | Pipe Plug | Steel |
| 4 | Bolt, Impeller | Stainless Steel |
| 5 | Washer, Impeller | Stainless Steel |
| 6 | Closed Impeller | Cast Iron |
| 7① | O-Ring | BUNA-N |
| 8 | Diecut Gasket | Lexide |
| 10 | Seal Housing | Cast Iron |
| 17① | Single Mechanical Seal | Miscellaneous |
| 24 | Shaft Sleeve | Stainelss Steel |
| 27 | Pipe Plug | Steel |
| 37 | Impeller Key | Steel |

| Item No. | Description | Materials |
|----------|-----------------|-----------------|
| 46 | Diffuser | Cast Iron |
| 49 | Diecut Gasket | Lexide |
| 50 | Suction Inlet | Cast Iron |
| 51① | Check Valve | BUNA-N |
| 53 | Keeper | Stainless Steel |
| 54 | Bolt, Shoulder | Stainless Steel |
| 63 | Slinger | Rubber |
| 67 | Motor Adapter | Cast Iron |
| 69 | Motor (specify) | — |
| 72 | Shim | Steel |
| 73 | Riser | Steel |

① Item Nos. 7, 17 and 51 are available in Viton® as an optional material.

Prime Line® 2P – 4P Frame Mounted Pumps Materials of Construction

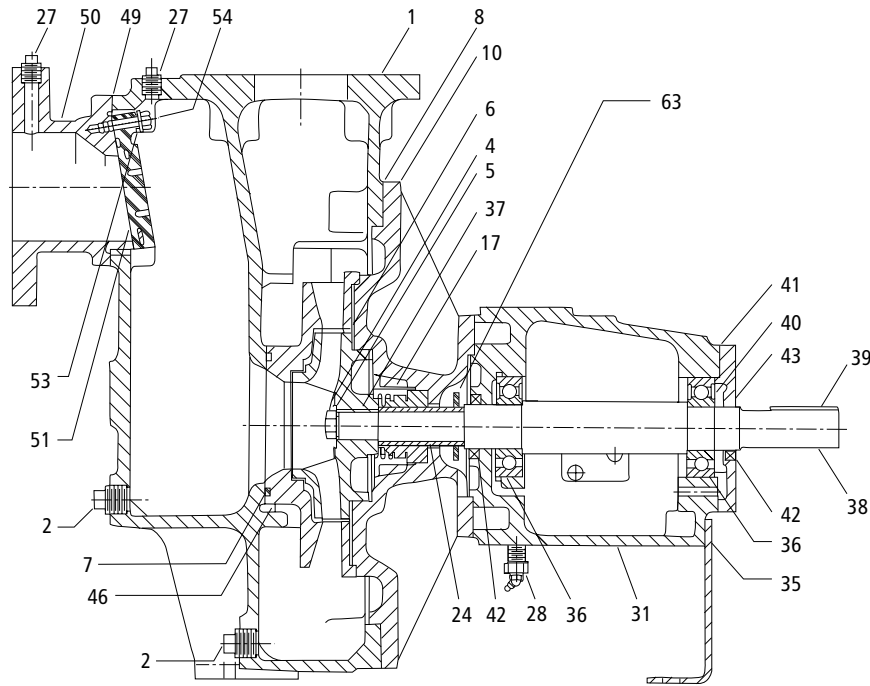

| Item No. | Description | Materials |
|-----------------|------------------------|-----------------|
| 1 | Casing | Cast Iron |
| 2 | Pipe Plug | Steel |
| 4 | Bolt, Impeller | Stainless Steel |
| 5 | Washer, Impeller | Stainless Steel |
| 6 | Closed Impeller | Cast Iron |
| 7 ^① | O-Ring | BUNA-N |
| 8 | Diecut Gasket | Lexide |
| 10 | Seal Housing | Cast Iron |
| 17 ^① | Single Mechanical Seal | Miscellaneous |
| 24 | Shaft Sleeve | Stainless Steel |
| 28 | Grease Fitting | Steel |
| 31 | Bearing Housing | Cast Iron |
| 35 | Mounting Foot | Steel |
| 36 | Bearing | Steel |

| Item No. | Description | Materials |
|-----------------|------------------|-----------------|
| 37 | Impeller Key | Steel |
| 38 | Shaft | Steel |
| 39 | Coupling Key | Steel |
| 40 | Bearing Retainer | Steel |
| 41 | Diecut Gasket | Steel |
| 42 | Lip Seal | BUNA/Steel |
| 43 | Bearing Cap | Cast Iron |
| 46 | Diffuser | Cast Iron |
| 49 | Diecut Gasket | Lexide |
| 50 | Inlet Suction | Cast Iron |
| 51 ^① | Check Valve | BUNA-N |
| 53 | Keeper | Stainless Steel |
| 54 | Bolt, Shoulder | Stainless Steel |
| 63 | Slinger | Rubber |

^① Item Nos. 7, 17 and 51 are available in Viton as an optional material.

Goulds Pumps

Commercial Water

Prime Line® 4E and 6E Pumps — Materials of Construction

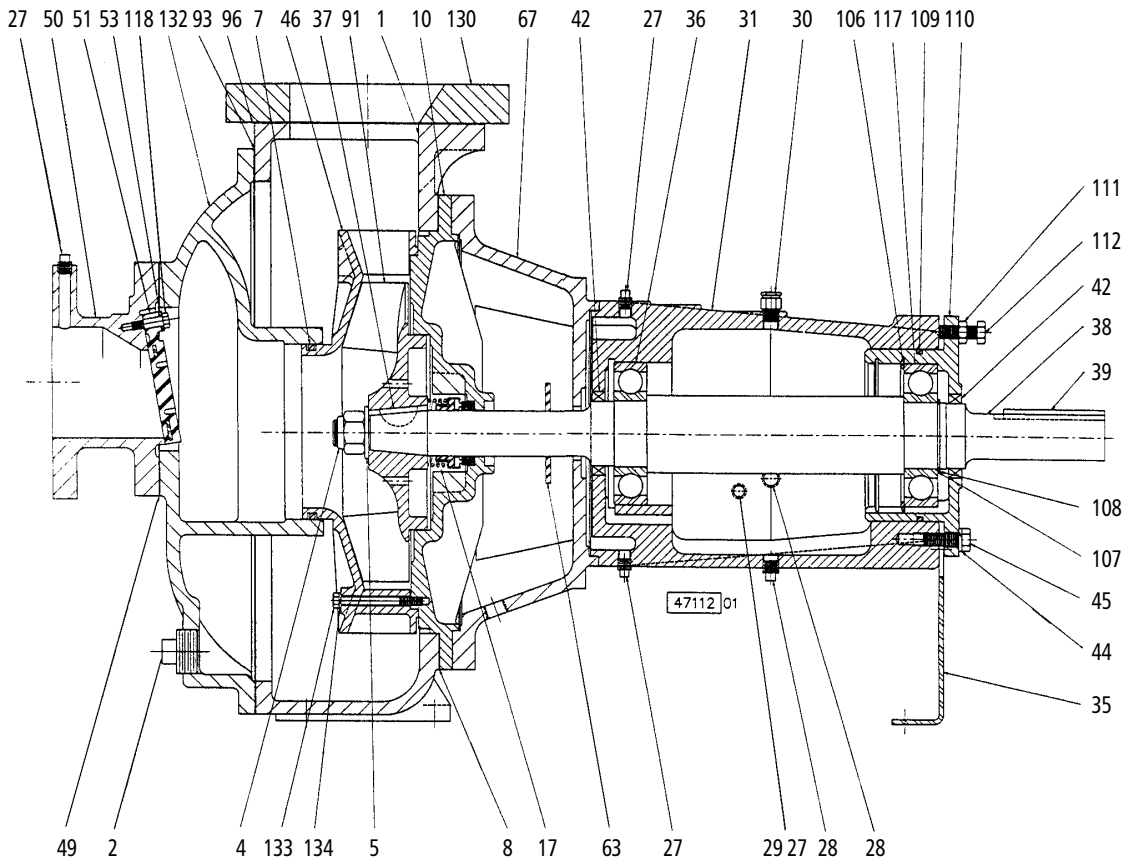

| Item No. | Description | Materials |
|----------|-------------------------|--------------------|
| 1 | Casing | Ductile Iron |
| 2 | Pipe Plug | Cast Iron |
| 4 | Locknut, Impeller | Steel |
| 5 | Washer, Curved | Stainless Steel |
| 7* | O-Ring | Buna-N Rubber |
| 8 | Gasket, Diecut | Composite |
| 10 | Housing Seal | Cast Iron |
| 17* | Seal, Single Mechanical | Carbon vs. Ceramic |
| 27 | Pipe Plug | Steel |
| 28 | Pipe Plug | Steel |
| 29 | Oiler (optional) | — |
| 30 | Vent, Filter | Steel |
| 31 | Housing, Bearing | Cast Iron |
| 35 | Foot, Mounting | Steel |
| 36 | Bearing | #313 |
| 37 | Key, Impeller | Steel |
| 38 | Shaft | Steel |
| 39 | Key, Coupling | Steel |
| 42 | Retainer | Steel/Rubber |
| 44 | Lockwasher | Stainless Steel |
| 45 | Capscrew | Stainless Steel |

| Item No. | Description | Materials |
|----------|------------------|-----------------|
| 46 | Diffuser | Cast Iron |
| 49 | Gasket, Diecut | Composite |
| 50 | Inlet, Suction | Cast Iron |
| 51* | Valve, Check | Buna-N Rubber |
| 53 | Keeper | Stainless Steel |
| 63 | Slinger | PVC |
| 67 | Bracket | Cast Iron |
| 91 | Impeller | Cast Iron |
| 93 | Gasket, Diecut | Composite |
| 96 | Gasket, Diecut | Composite |
| 106 | Ring, Retaining | Steel |
| 107 | Shim, Bearing | Steel |
| 108 | Ring, Retaining | Steel |
| 109 | O-Ring | Buna-N Rubber |
| 110 | Carrier, Bearing | Cast Iron |
| 111 | Hexnut, Jam | Stainless Steel |
| 118 | Bolt, Shouldered | Stainless Steel |
| 130 | Adapter, Plate | Cast Iron |
| 132 | Cover, Casing | Cast Iron |
| 133 | Capscrew | Stainless Steel |
| 134 | Lockwasher | Stainless Steel |

*Available in Viton® as an option.

Prime Line® Performance Coverage (60 Hz) 4E and 6E

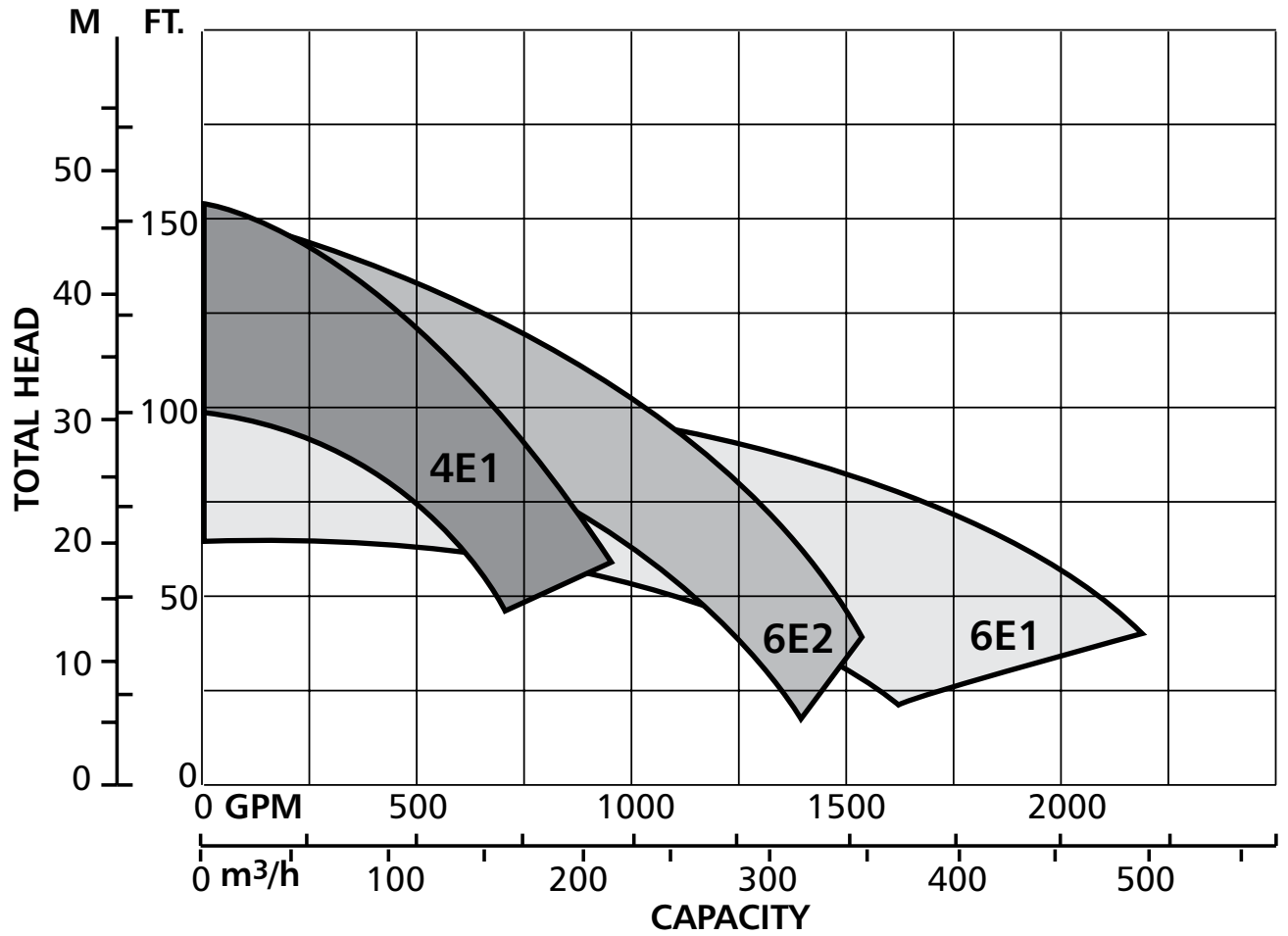

Goulds Pumps

Commercial Water

Prime Line® Performance Curves – Size 2P1, 60 Hz

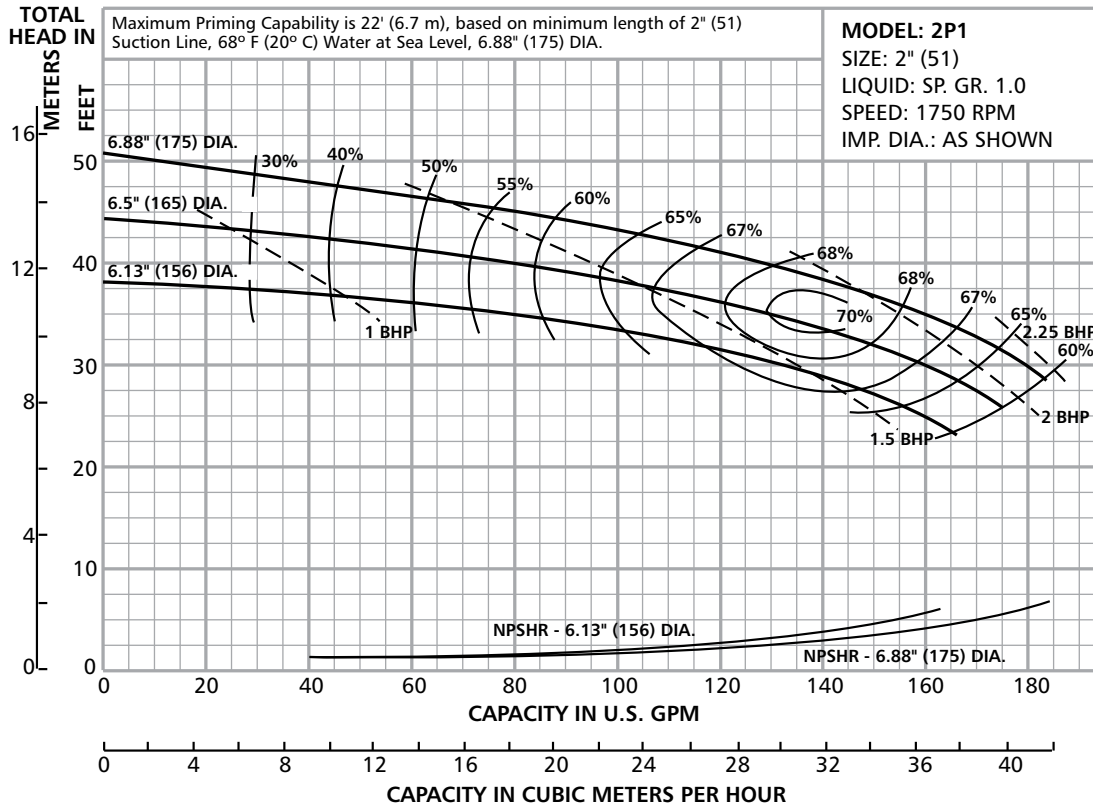

| Ordering Code | Standard HP Rating | Imp. Dia. ① |
|---------------|--------------------|-------------|
| A | 3 | 6.88 (175) |
| B | 2 | 6.5 (165) |
| C | 1½* | 6.13 (156) |

* Requires service factor.

① Impeller diameter in inches and millimeters (mm).

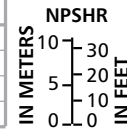

Prime Line® Performance Curves – Size 2P1, 50 Hz

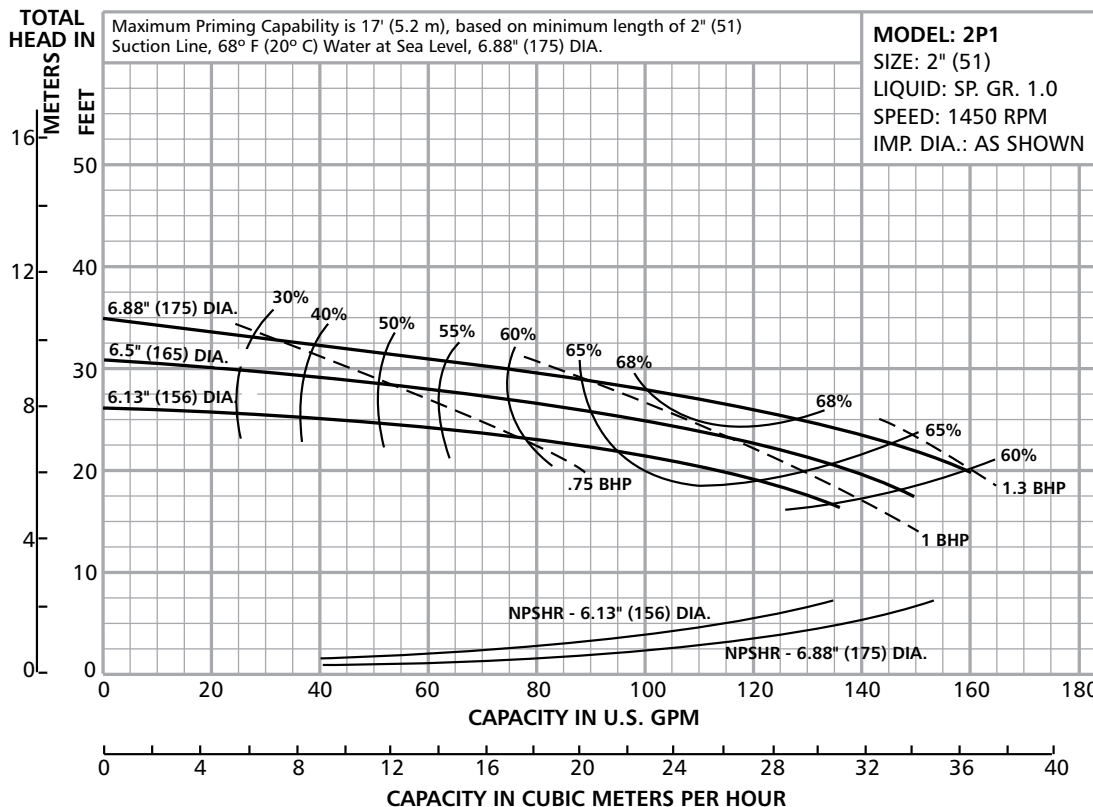

| Ordering Code | Standard HP Rating | Imp. Dia. ① |
|---------------|--------------------|-------------|
| A | 1½ | 6.88 (175) |
| B | 1½ | 6.5 (165) |
| C | 1 | 6.13 (156) |

① Impeller diameter in inches and millimeters (mm).

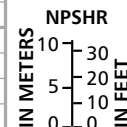

Prime Line® Performance Curves – Size 2P2, 60 Hz

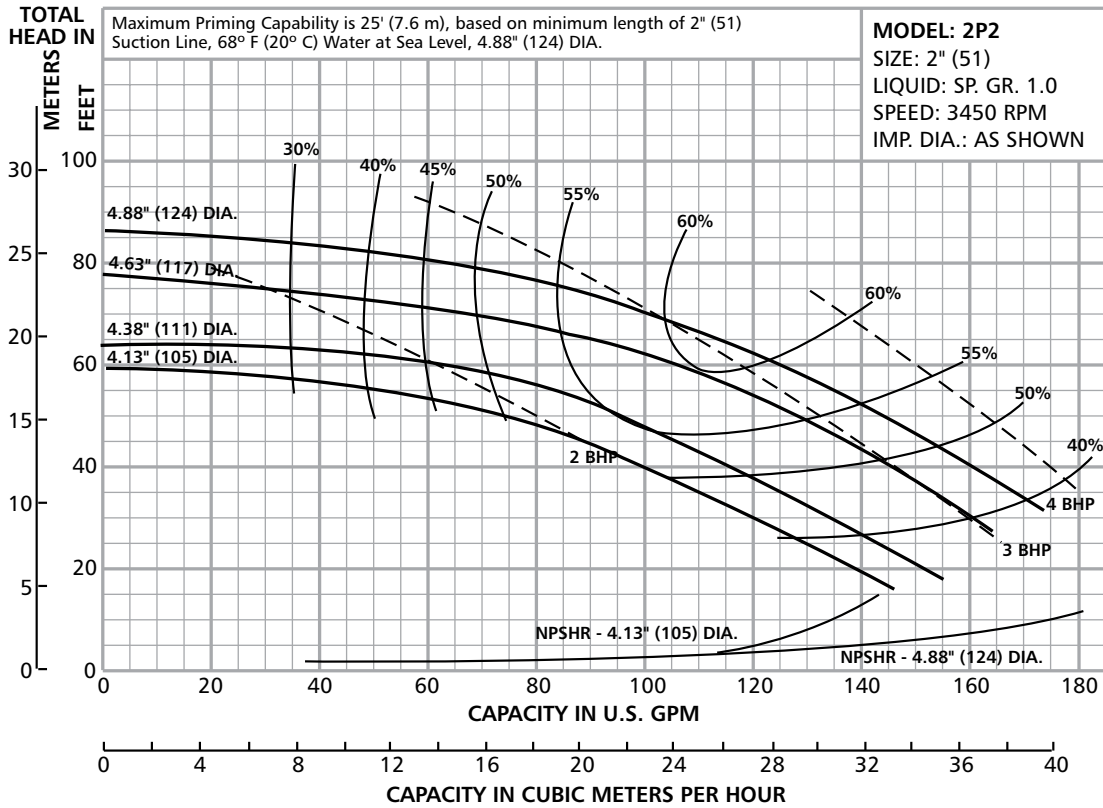

| Ordering Code | Standard HP Rating | Imp. Dia. ① |
|---------------|--------------------|-------------|
| A | 5 | 4.88 (124) |
| B | 3* | 4.63 (117) |
| C | 3 | 4.38 (111) |
| D | 2* | 4.13 (105) |

* Requires service factor.

① Impeller diameter in inches and millimeters (mm).

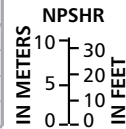

Prime Line® Performance Curves – Size 2P2, 50 Hz

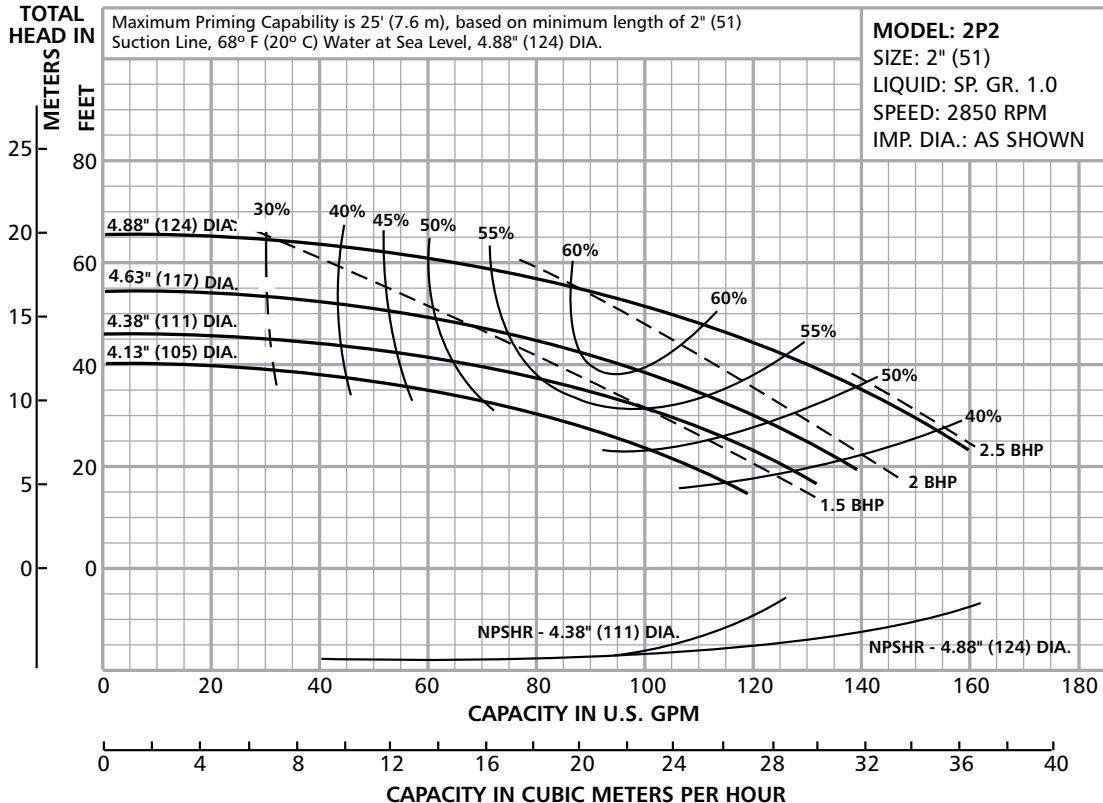

| Ordering Code | Standard HP Rating | Imp. Dia. ① |
|---------------|--------------------|-------------|
| A | 3 | 4.88 (124) |
| B | 2 | 4.63 (117) |
| C | 1½* | 4.38 (111) |
| D | 1½ | 4.13 (105) |

* Requires service factor.

① Impeller diameter in inches and millimeters (mm).

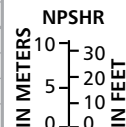

Goulds Pumps

Commercial Water

Prime Line® Performance Curves – Size 2P3, 60 Hz

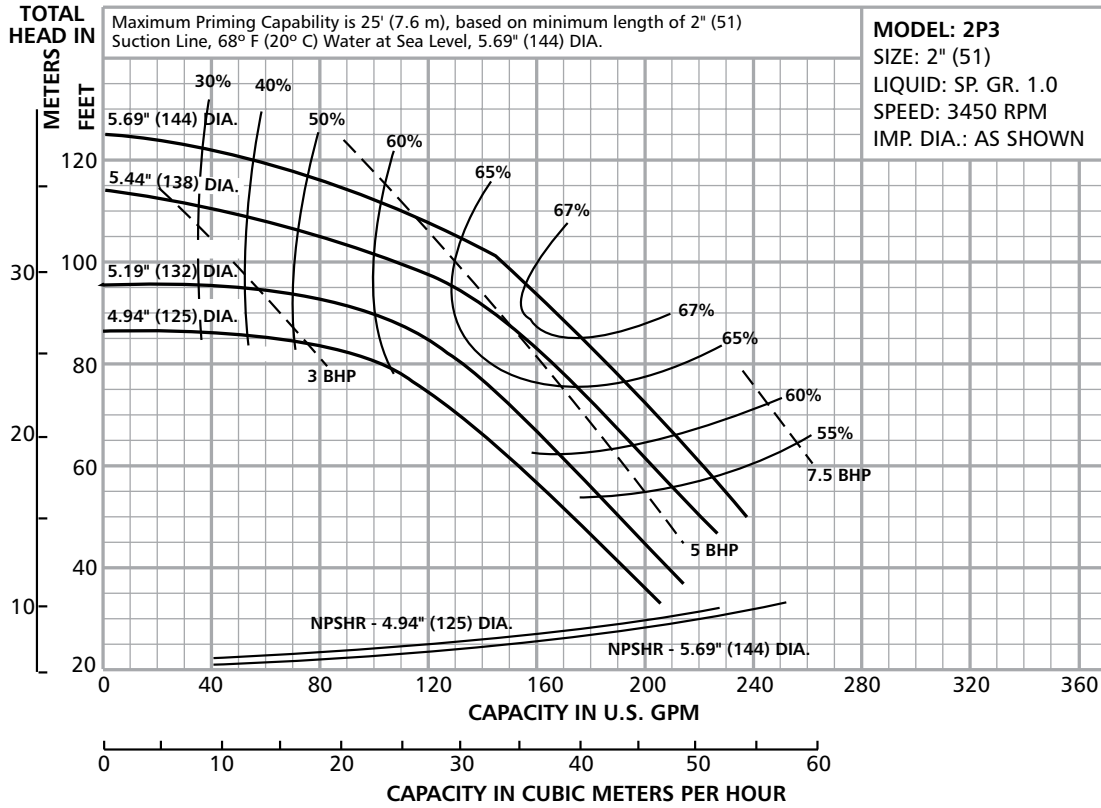

| Ordering Code | Standard HP Rating | Imp. Dia. ① |
|---------------|--------------------|-------------|
| A | 7½ | 5.69 (144) |
| B | 7½ | 5.44 (138) |
| C | 5* | 5.19 (132) |
| D | 5 | 4.94 (125) |

* Requires service factor.

① Impeller diameter in inches and millimeters (mm).

Prime Line® Performance Curves – Size 2P3, 50 Hz

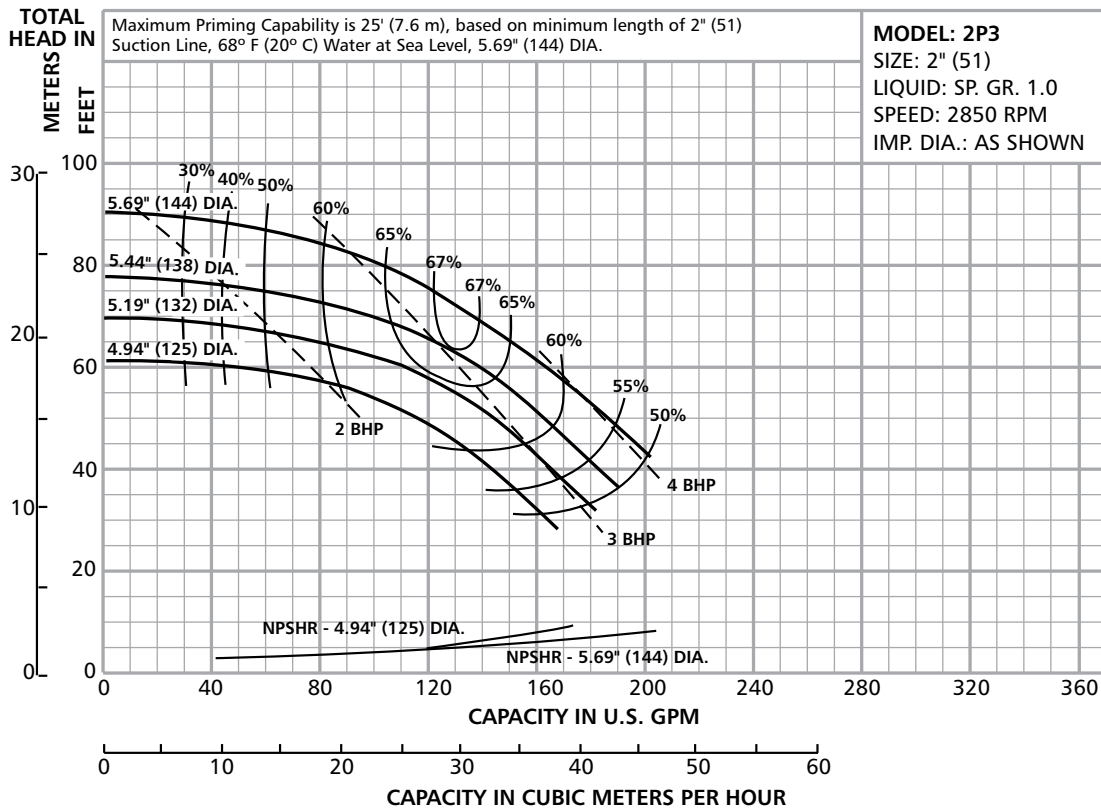

| Ordering Code | Standard HP Rating | Imp. Dia. ① |
|---------------|--------------------|-------------|
| A | 5 | 5.69 (144) |
| B | 5 | 5.44 (138) |
| C | 3* | 5.19 (132) |
| D | 3 | 4.94 (125) |

* Requires service factor.

① Impeller diameter in inches and millimeters (mm).

Prime Line® Performance Curves – Size 2P4, 60 Hz

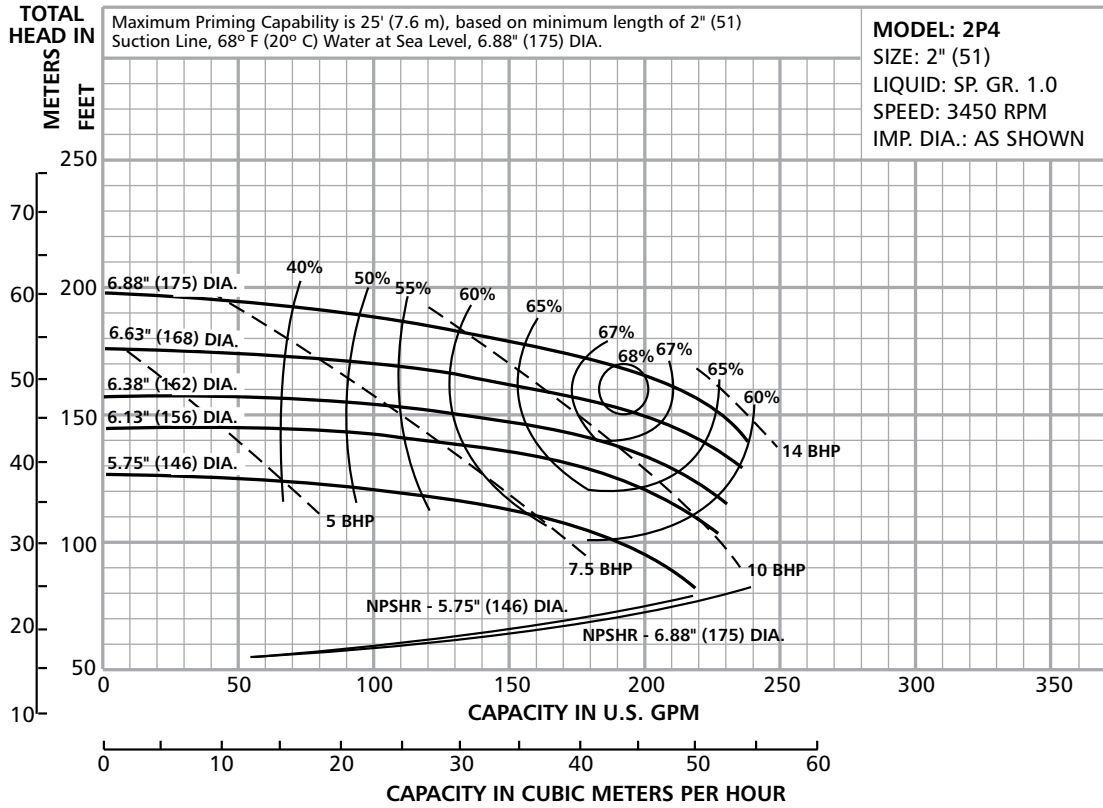

| Ordering Code | Standard HP Rating | Imp. Dia. ① |
|---------------|--------------------|-------------|
| A | 15 | 6.88 (175) |
| B | 15 | 6.63 (168) |
| C | 10* | 6.38 (162) |
| D | 10 | 6.13 (156) |
| E | 7½* | 5.75 (146) |

* Requires service factor.
 ① Impeller diameter in inches and millimeters (mm).

Prime Line® Performance Curves – Size 2P4, 50 Hz

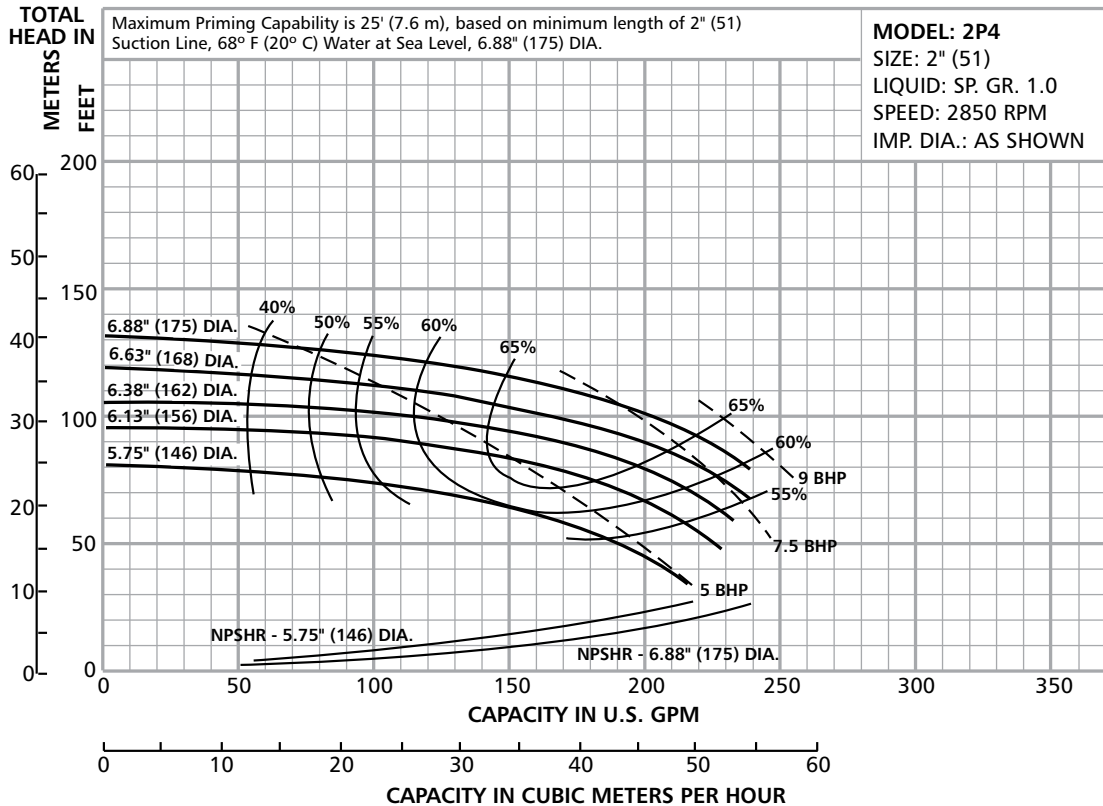

| Ordering Code | Standard HP Rating | Imp. Dia. ① |
|---------------|--------------------|-------------|
| A | 10 | 6.88 (175) |
| B | 7½* | 6.63 (168) |
| C | 7½ | 6.38 (162) |
| D | 7½ | 6.13 (156) |
| E | 5 | 5.75 (146) |

* Requires service factor.
 ① Impeller diameter in inches and millimeters (mm).

Goulds Pumps

Commercial Water

Prime Line® Performance Curves – Size 3P1, 60 Hz

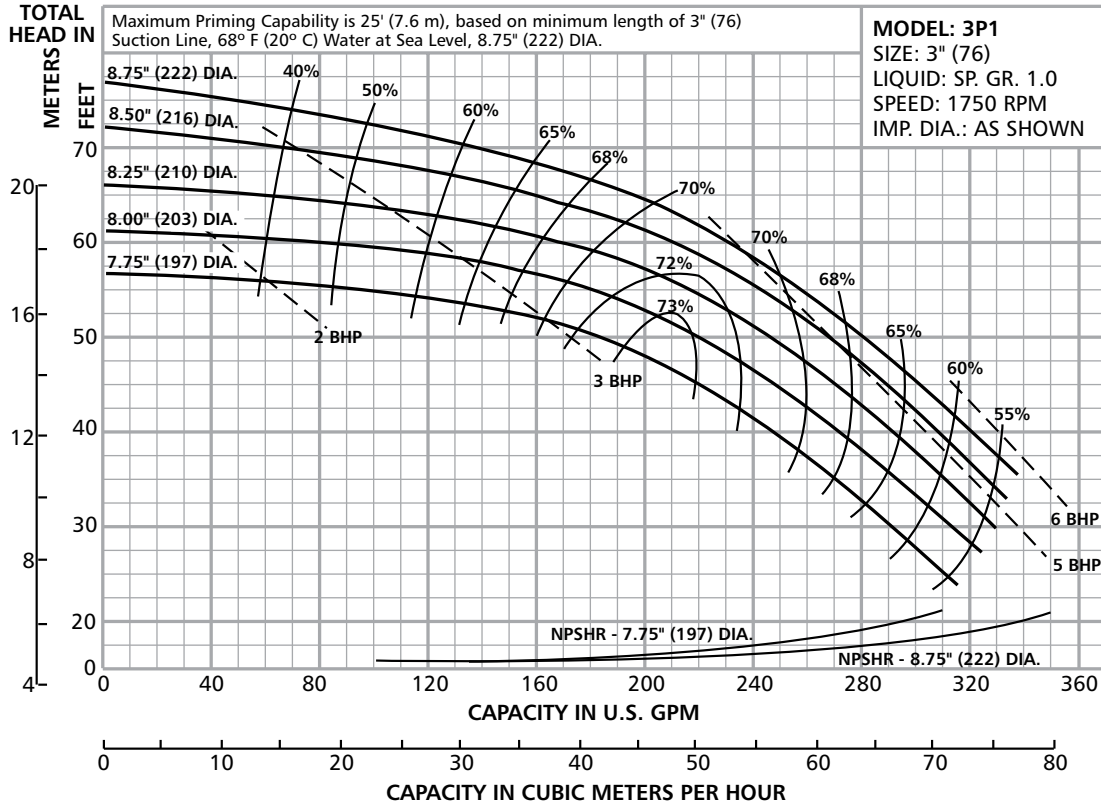

| Ordering Code | Standard HP Rating | Imp. Dia. ① |
|---------------|--------------------|-------------|
| A | 5* | 8.75 (222) |
| B | 5* | 8.50 (216) |
| C | 5 | 8.25 (210) |
| D | 5 | 8.00 (203) |
| E | 5 | 7.75 (197) |

* Requires service factor.

① Impeller diameter in inches and millimeters (mm).

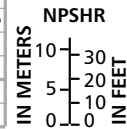

Prime Line® Performance Curves – Size 3P1, 50 Hz

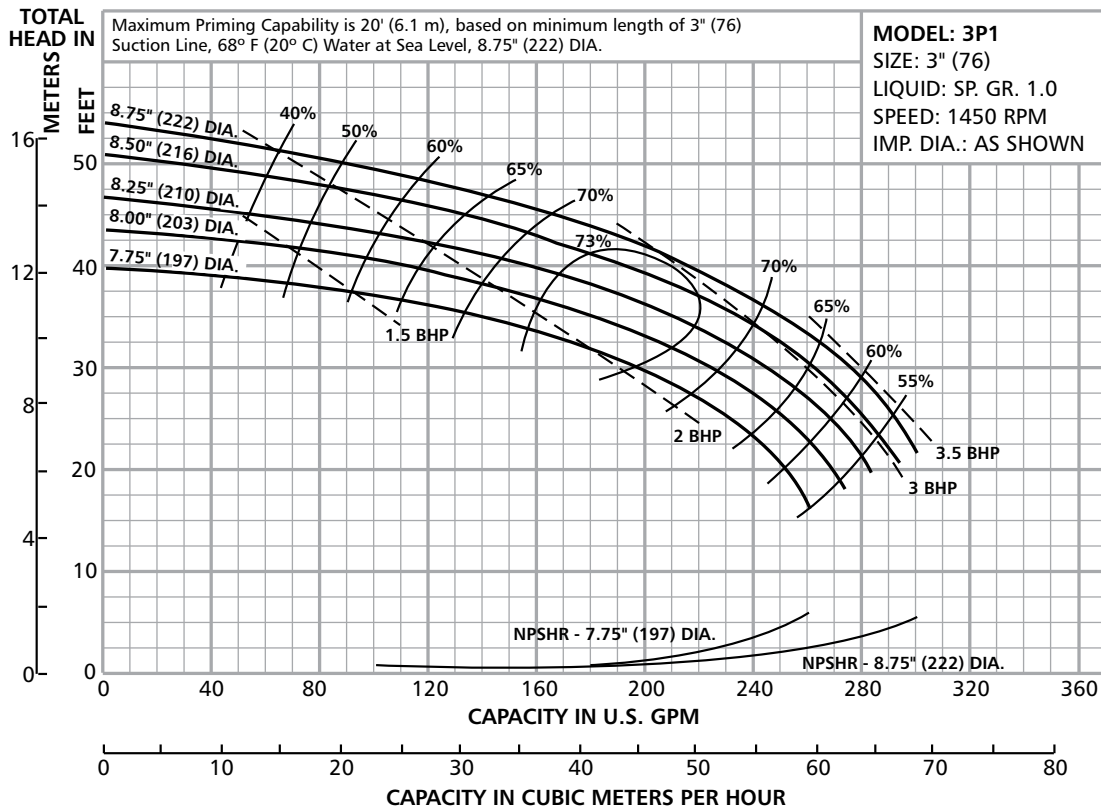

| Ordering Code | Standard HP Rating | Imp. Dia. ① |
|---------------|--------------------|-------------|
| A | 5 | 8.75 (222) |
| B | 3* | 8.50 (216) |
| C | 3 | 8.25 (210) |
| D | 3 | 8.00 (203) |
| E | 3 | 7.75 (197) |

* Requires service factor.

① Impeller diameter in inches and millimeters (mm).

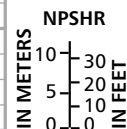

Prime Line® Performance Curves – Size 3P2, 60 Hz

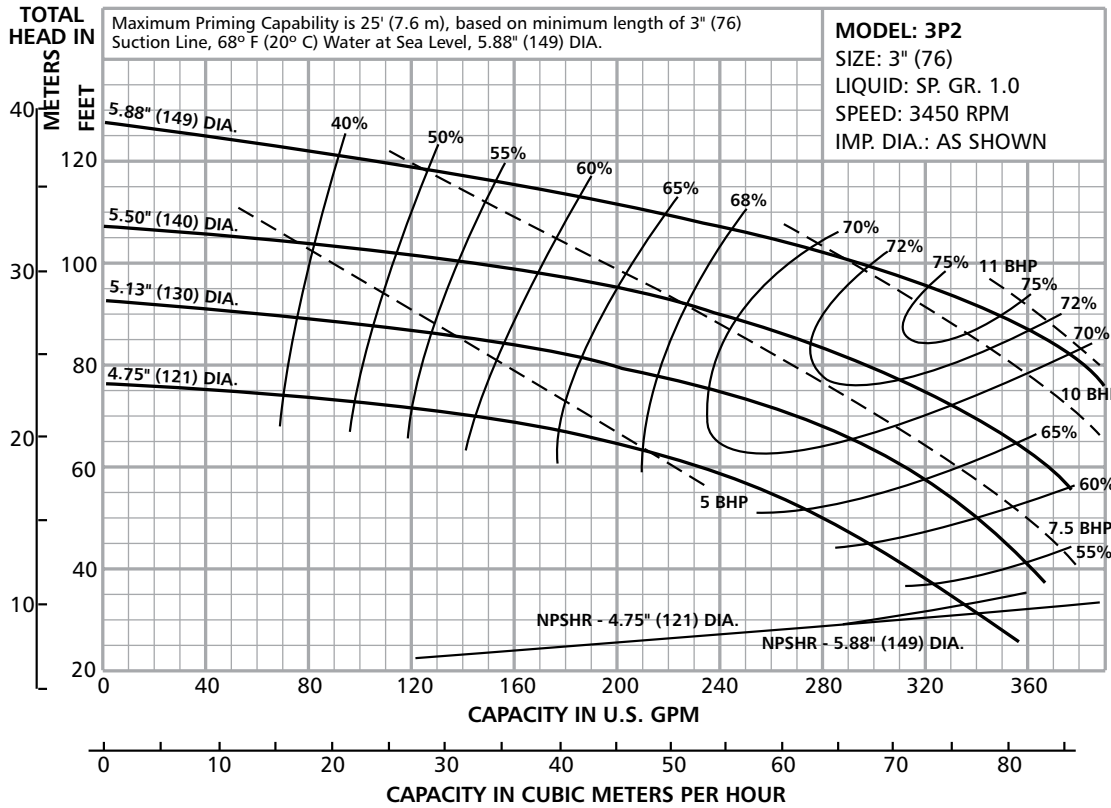

| Ordering Code | Standard HP Rating | Imp. Dia. ① |
|---------------|--------------------|-------------|
| A | 10* | 5.88 (149) |
| B | 10 | 5.50 (140) |
| C | 7½ | 5.13 (130) |
| D | 5* | 4.75 (121) |

* Requires service factor.

① Impeller diameter in inches and millimeters (mm).

Prime Line® Performance Curves – Size 3P2, 50 Hz

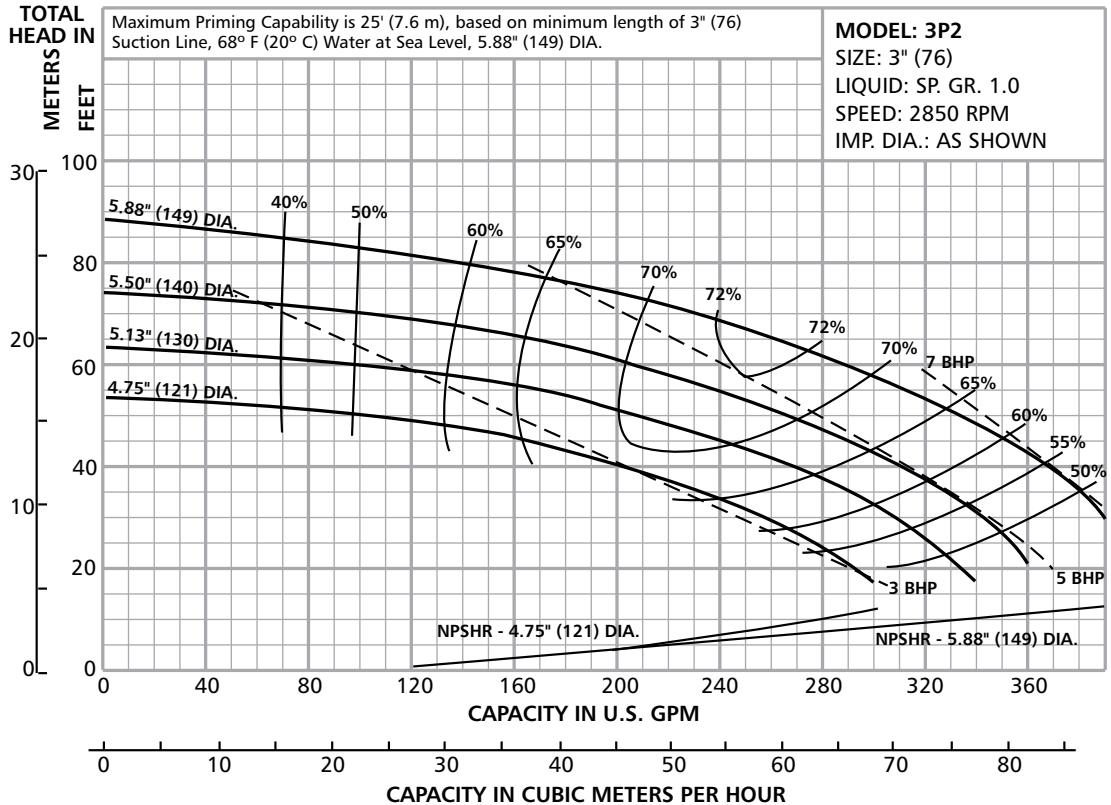

| Ordering Code | Standard HP Rating | Imp. Dia. ① |
|---------------|--------------------|-------------|
| A | 7½ | 5.88 (149) |
| B | 5 | 5.50 (140) |
| C | 5 | 5.13 (130) |
| D | 3* | 4.75 (121) |

* Requires service factor.

① Impeller diameter in inches and millimeters (mm).

Goulds Pumps

Commercial Water

Prime Line® Performance Curves – Size 3P3, 60 Hz, 3500 RPM

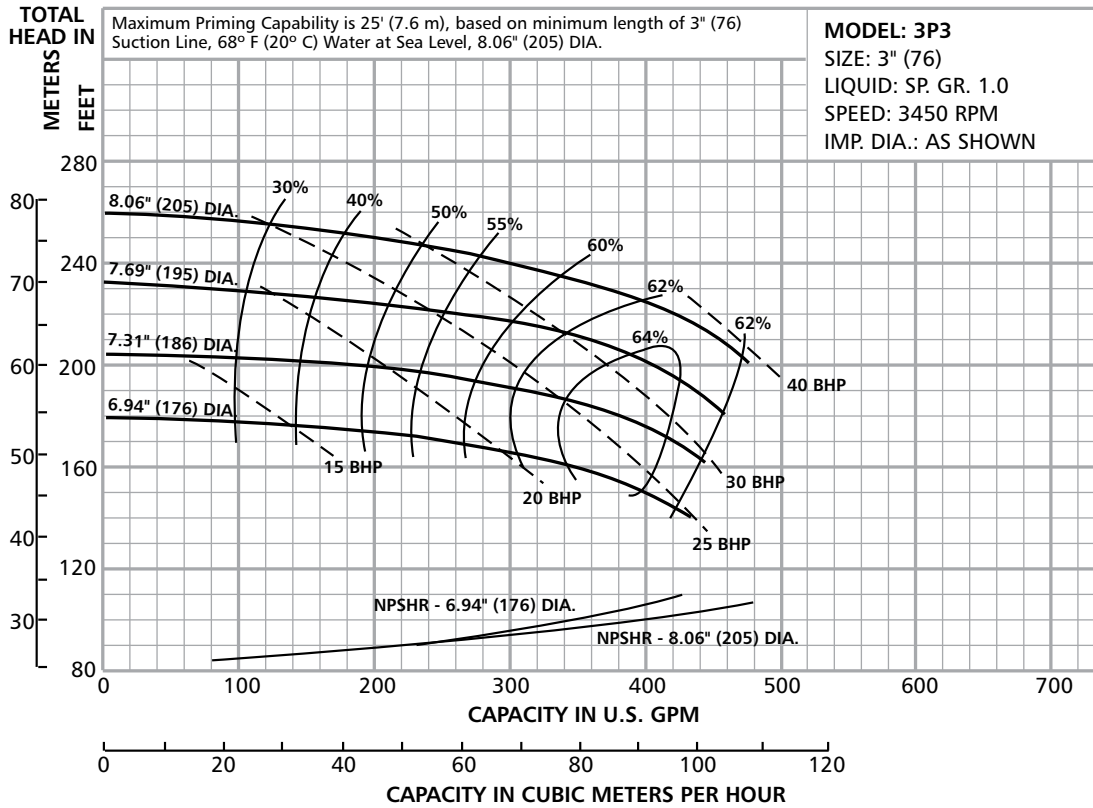

| Ordering Code | Standard HP Rating | Imp. Dia. ① |
|---------------|--------------------|-------------|
| A | 40 | 8.06 (205) |
| B | 40 | 7.69 (195) |
| C | 30 | 7.31 (186) |
| D | 25 | 6.94 (176) |

① Impeller diameter in inches and millimeters (mm).

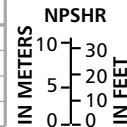

Prime Line® Performance Curves – Size 3P3, 50 Hz

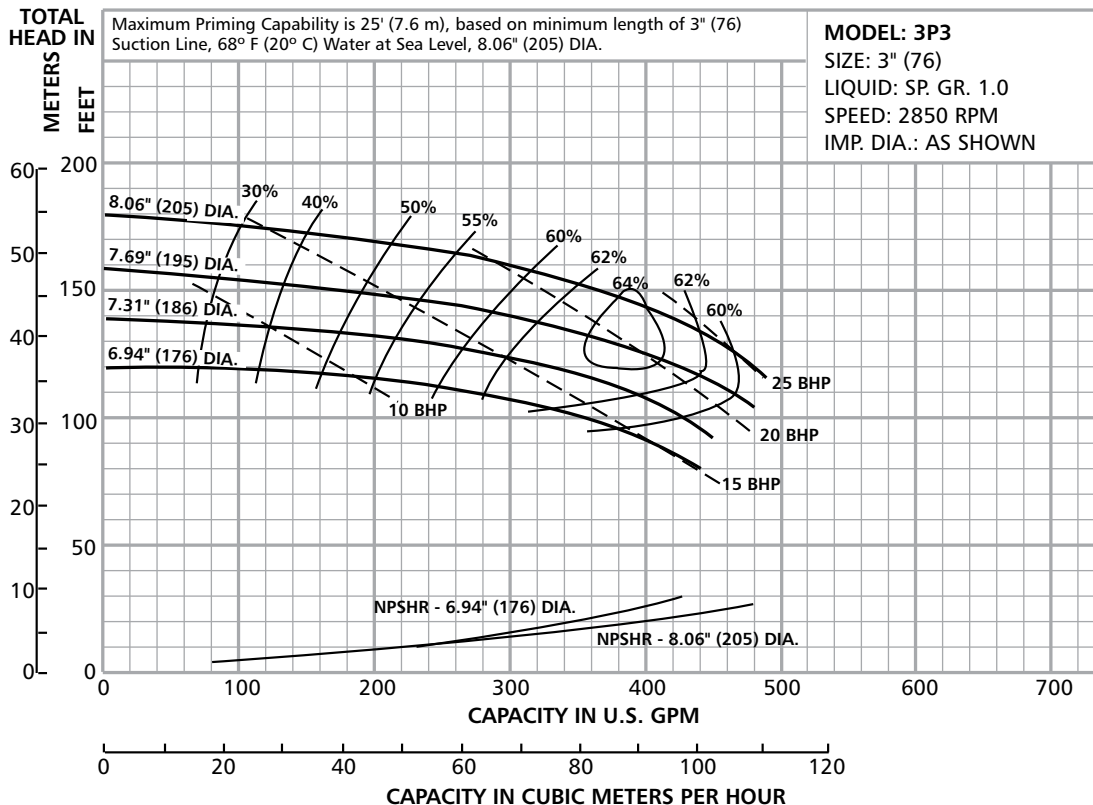

| Ordering Code | Standard HP Rating | Imp. Dia. ① |
|---------------|--------------------|-------------|
| A | 25 | 8.06 (205) |
| B | 25 | 7.69 (195) |
| C | 20 | 7.31 (186) |
| D | 15 | 6.94 (176) |

① Impeller diameter in inches and millimeters (mm).

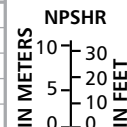

Prime Line® Performance Curves – Size 3P3, 60 Hz, 1750 RPM

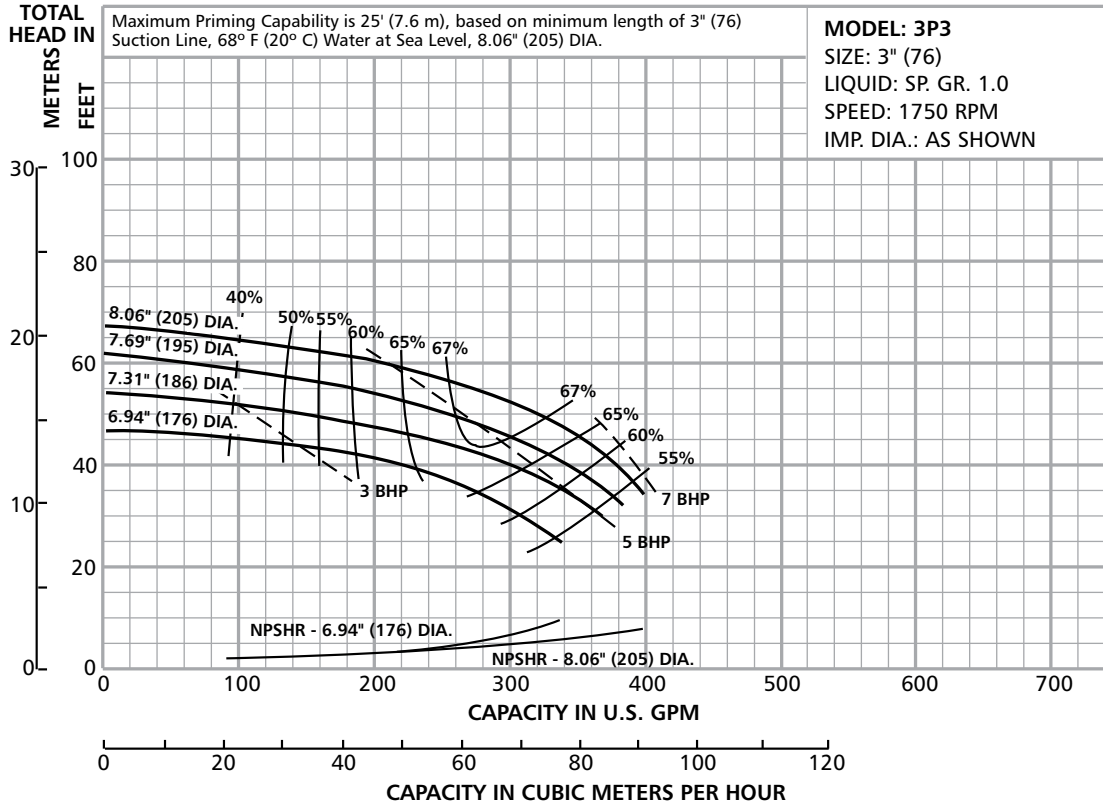

Prime Line® Performance Curves – Size 3P4, 60 Hz, 3450 RPM

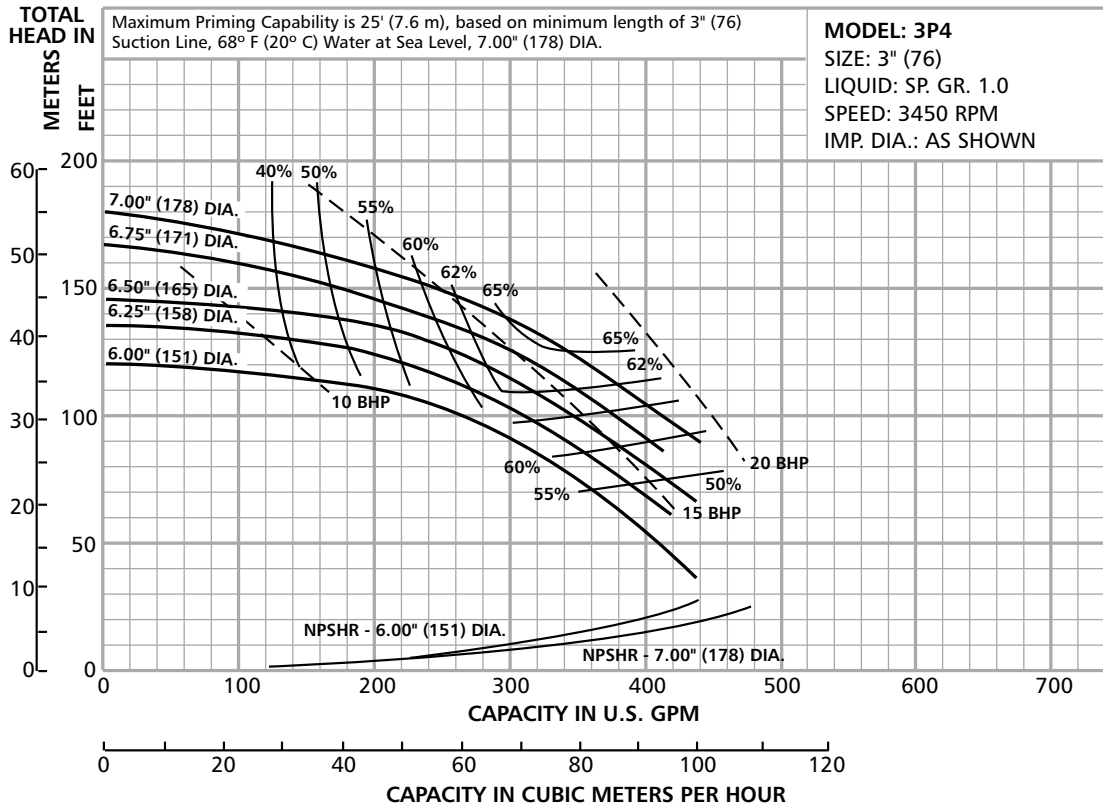

Goulds Pumps

Commercial Water

Prime Line® Performance Curves – Size 3P4, 50 Hz, 2850 RPM

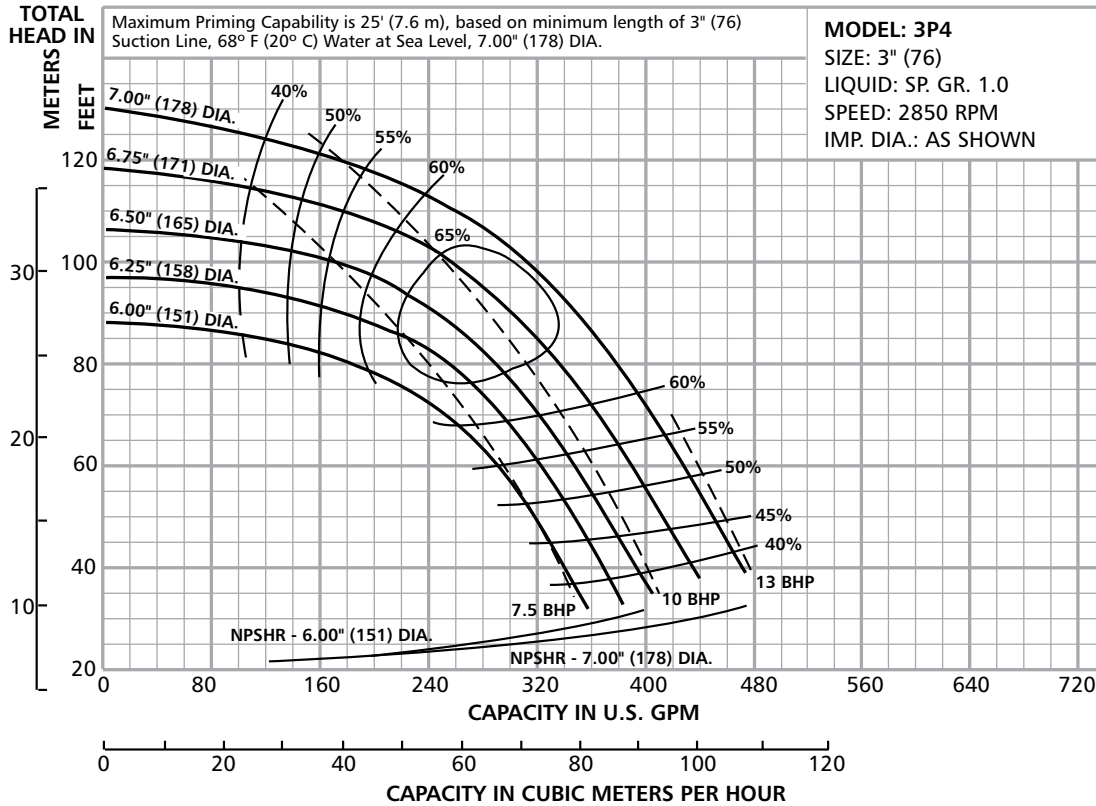

| Ordering Code | Standard HP Rating | Imp. Dia. ① |
|---------------|--------------------|-------------|
| A | 15 | 7.00 (178) |
| B | 15 | 6.75 (171) |
| C | 10 | 6.50 (165) |
| D | 10 | 6.25 (158) |
| E | 7½* | 6.00 (151) |

* Requires service factor.

① Impeller diameter in inches and millimeters (mm).

Prime Line® Performance Curves – Size 3P4, 60 Hz, 1750 RPM

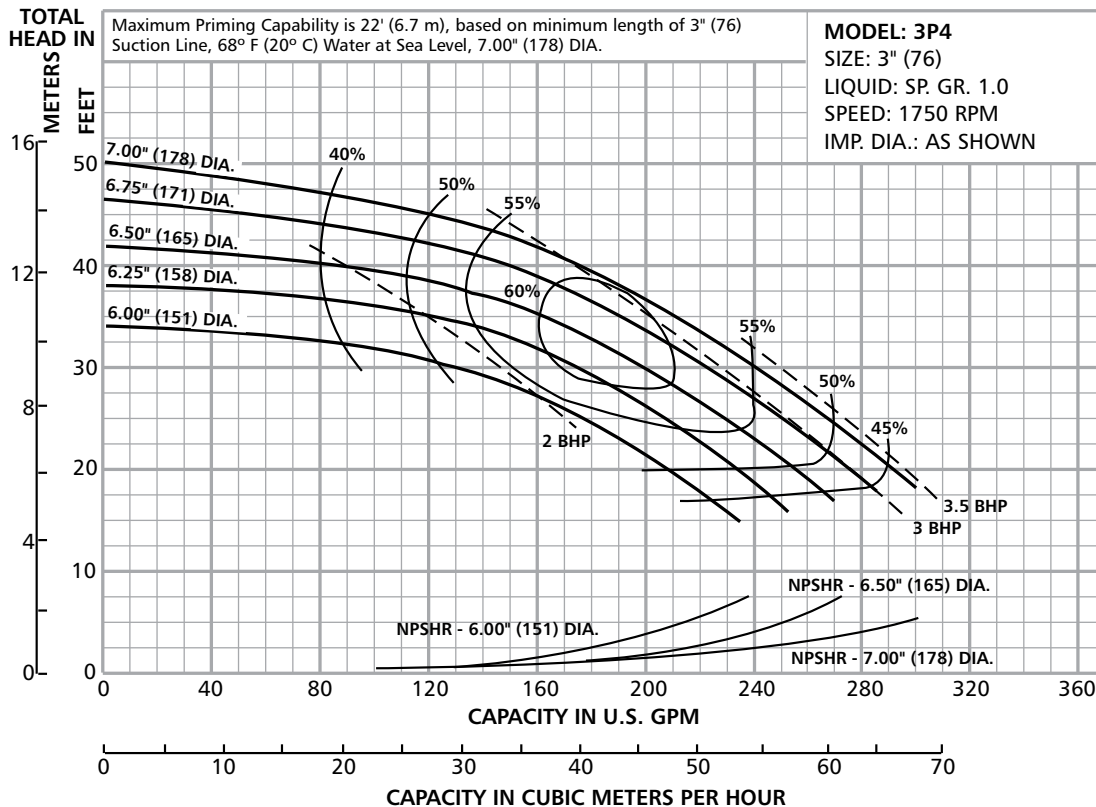

| Ordering Code | Standard HP Rating | Imp. Dia. ① |
|---------------|--------------------|-------------|
| A | 5 | 7.00 (178) |
| B | 3 | 6.75 (171) |
| C | 3 | 6.50 (165) |
| D | 3 | 6.25 (158) |
| E | 2* | 6.00 (151) |

* Requires service factor.

① Impeller diameter in inches and millimeters (mm).

Prime Line® Performance Curves – Size 4P1, 60 Hz, 1750 RPM

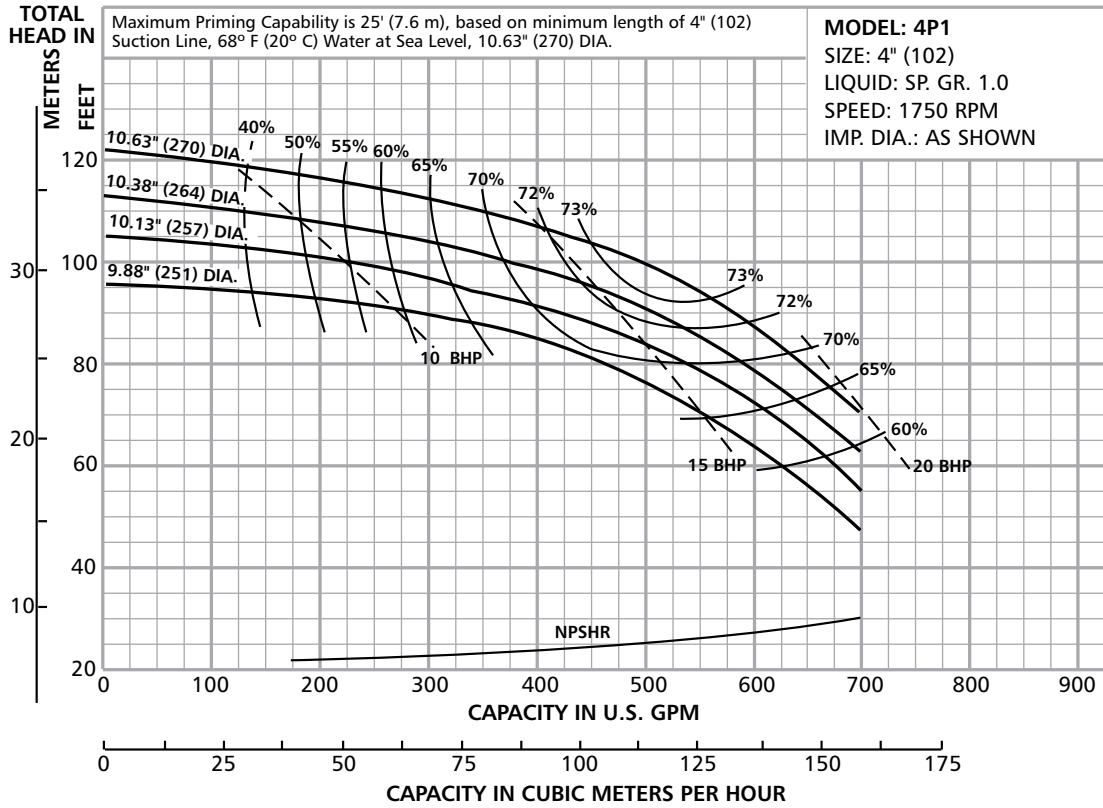

| Ordering Code | Standard HP Rating | Imp. Dia. ① |
|---------------|--------------------|-------------|
| A | 20 | 10.63 (270) |
| B | 20 | 10.38 (264) |
| C | 20 | 10.13 (257) |
| D | 15* | 9.88 (251) |

* Requires service factor.

① Impeller diameter in inches and millimeters (mm).

Prime Line® Performance Curves – Size 4P1, 50 Hz, 1450 RPM

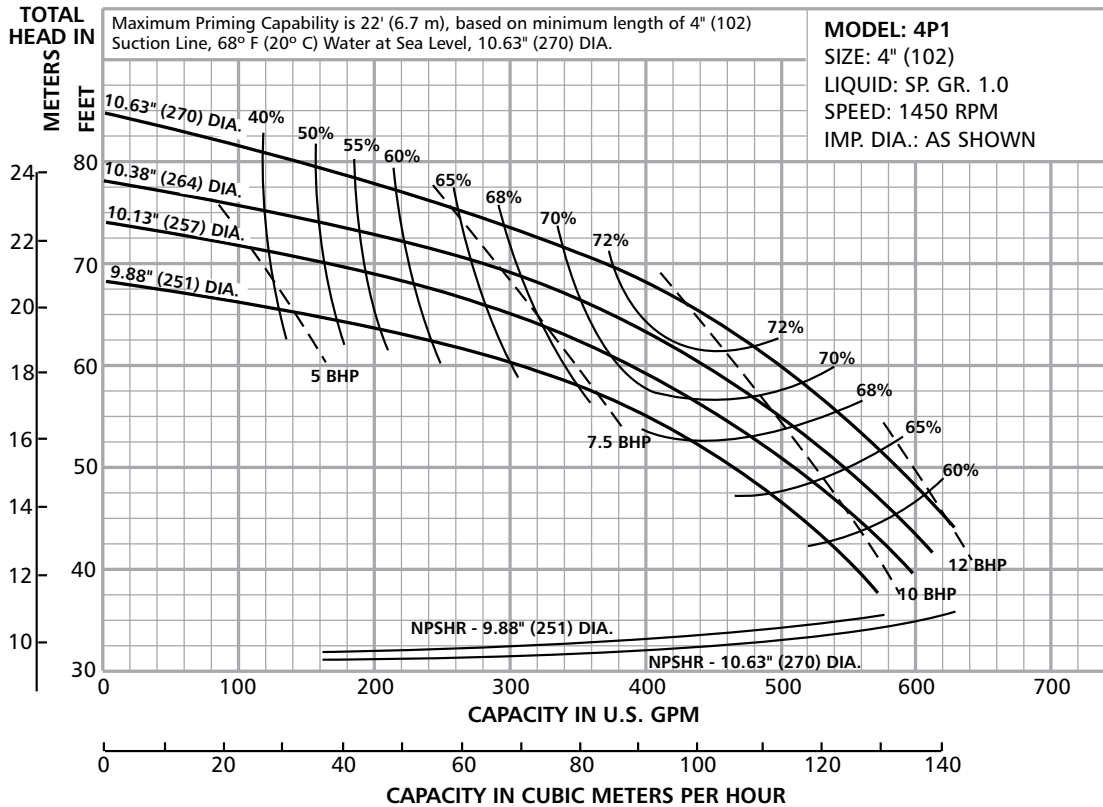

| Ordering Code | Standard HP Rating | Imp. Dia. ① |
|---------------|--------------------|-------------|
| A | 15 | 10.63 (270) |
| B | 15 | 10.38 (264) |
| C | 10* | 10.13 (257) |
| D | 10 | 9.88 (251) |

* Requires service factor.

① Impeller diameter in inches and millimeters (mm).

Goulds Pumps

Commercial Water

Prime Line® Performance Curves – Size 4P1, 60 Hz, 1150 RPM

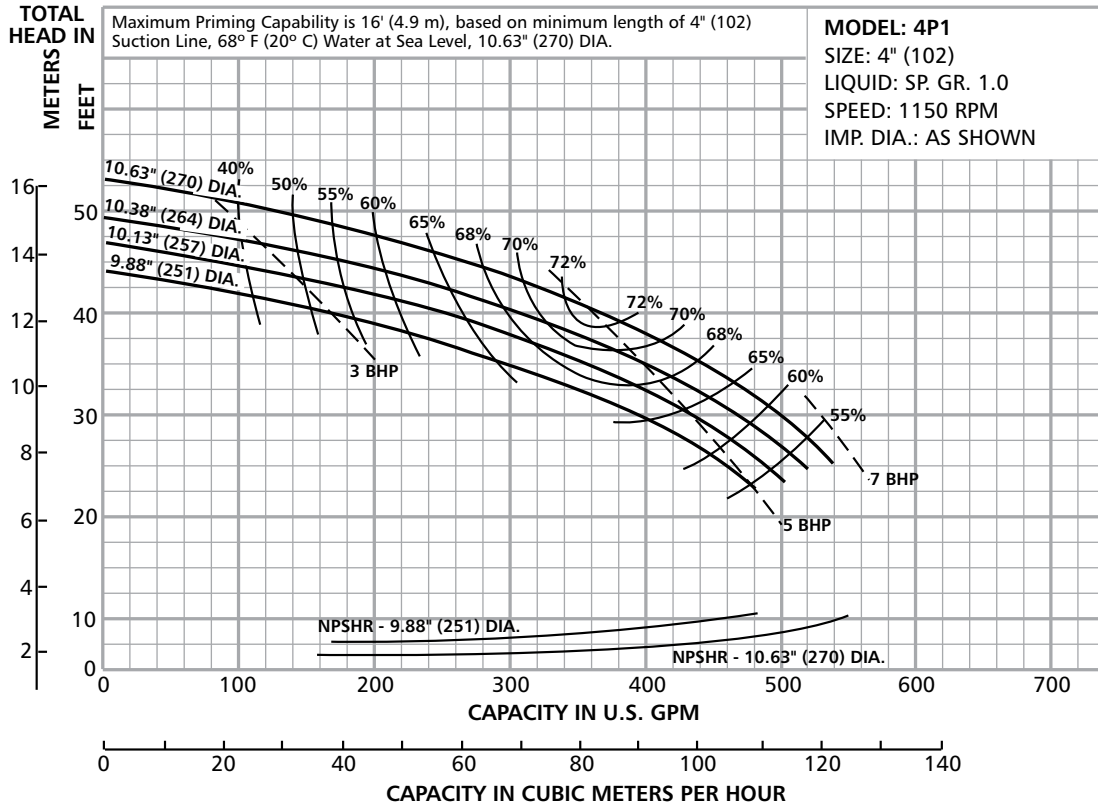

| Ordering Code | Standard HP Rating | Imp. Dia. ① |
|---------------|--------------------|-------------|
| A | 7½ | 10.63 (270) |
| B | 7½ | 10.38 (264) |
| C | 7½ | 10.13 (257) |
| D | 5 | 9.88 (251) |

① Impeller diameter in inches and millimeters (mm).

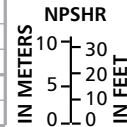

Prime Line® Performance Curves – Size 4P2, 60 Hz, 1750 RPM

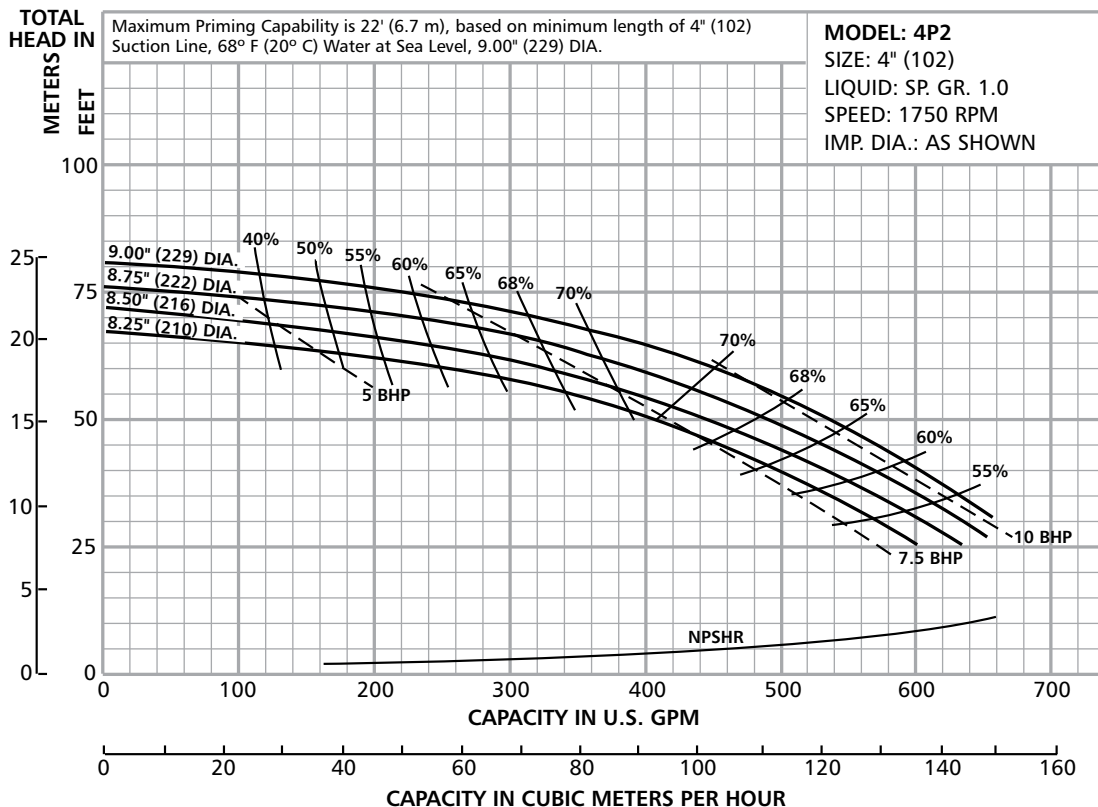

| Ordering Code | Standard HP Rating | Imp. Dia. ① |
|---------------|--------------------|-------------|
| A | 10* | 9.00 (229) |
| B | 10 | 8.75 (222) |
| C | 10 | 8.50 (216) |
| D | 7½* | 8.25 (210) |

* Requires service factor.

① Impeller diameter in inches and millimeters (mm).

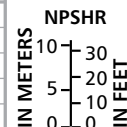

Prime Line® Performance Curves – Size 4P2, 50 Hz, 1450 RPM

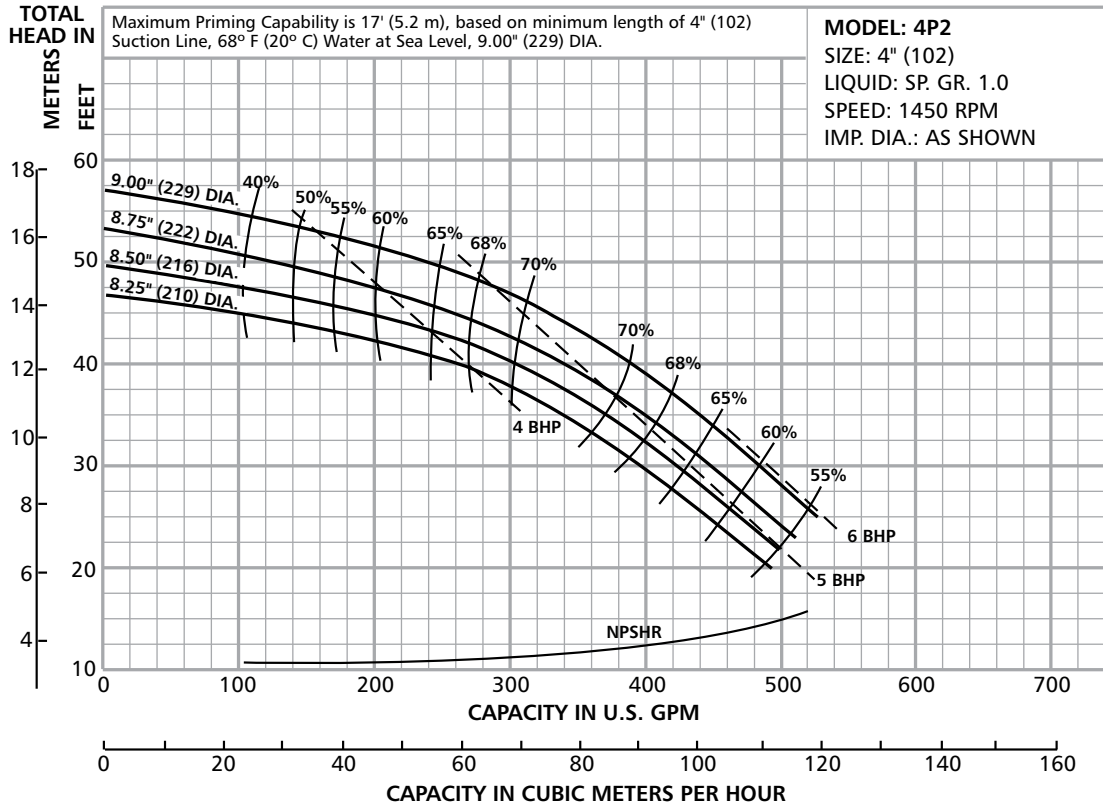

| Ordering Code | Standard HP Rating | Imp. Dia. ① |
|---------------|--------------------|-------------|
| A | 7½ | 9.00 (229) |
| B | 7½ | 8.75 (222) |
| C | 5 | 8.50 (216) |
| D | 5 | 8.25 (210) |

① Impeller diameter in inches and millimeters (mm).

Prime Line® Performance Curves – Size 4P2, 60 Hz, 1150 RPM

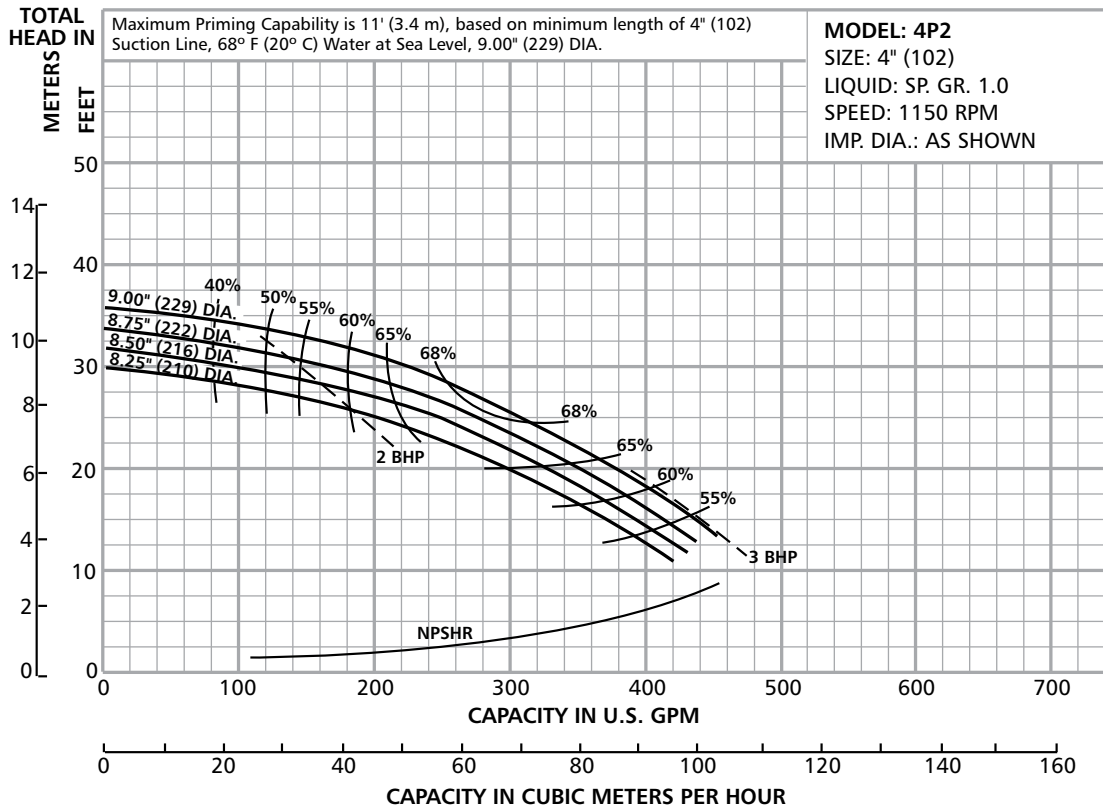

| Ordering Code | Standard HP Rating | Imp. Dia. ① |
|---------------|--------------------|-------------|
| A | 3 | 9.00 (229) |
| B | 3 | 8.75 (222) |
| C | 3 | 8.50 (216) |
| D | 3 | 8.25 (210) |

① Impeller diameter in inches and millimeters (mm).

Goulds Pumps

Commercial Water

Prime Line® Performance Curves – Size 4E1, 60 Hz, 1750 RPM

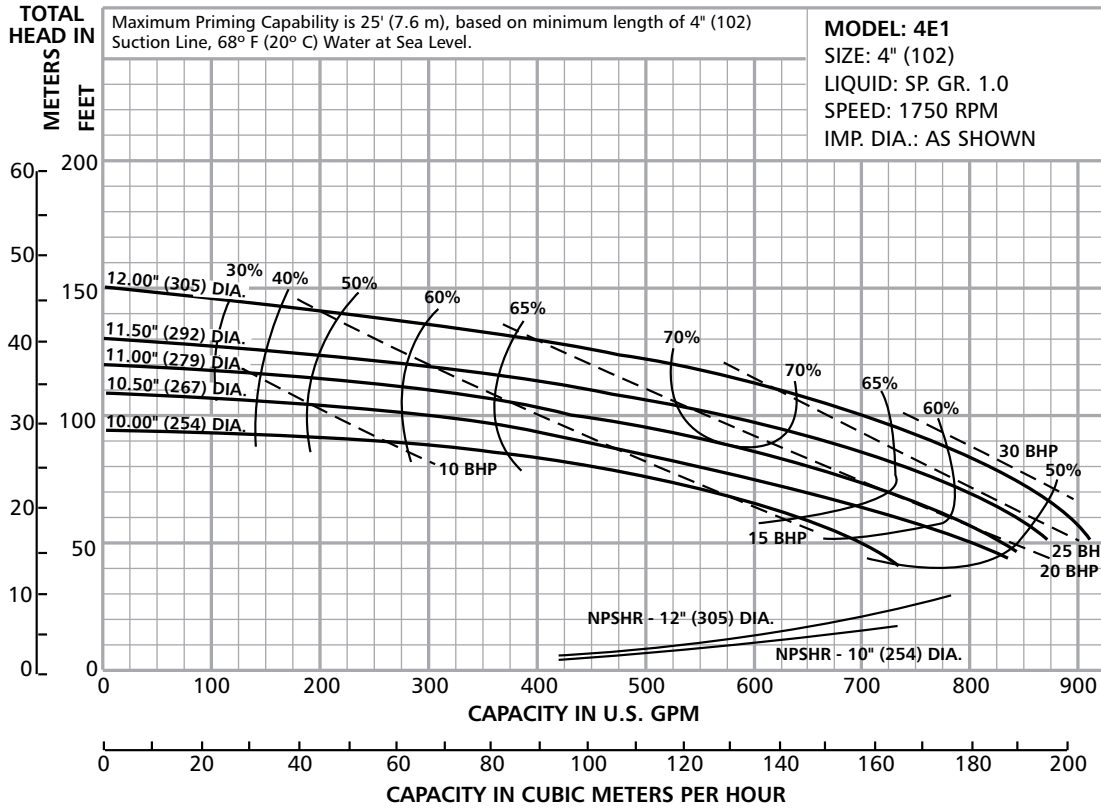

Maximum Priming Capability is:

| Ordering Code | Imp. Dia. | Max. Lift |
|---------------|-------------|-------------|
| A | 12.0" (305) | 25' (7.6 m) |
| B | 11.5" (292) | 22' (6.7 m) |
| C | 11.0" (279) | 19' (5.8 m) |
| D | 10.5" (267) | 17' (5.2 m) |
| E | 10.0" (254) | 16' (4.9 m) |

Prime Line® Performance Curves – Size 4E1, 50 Hz, 1450 RPM

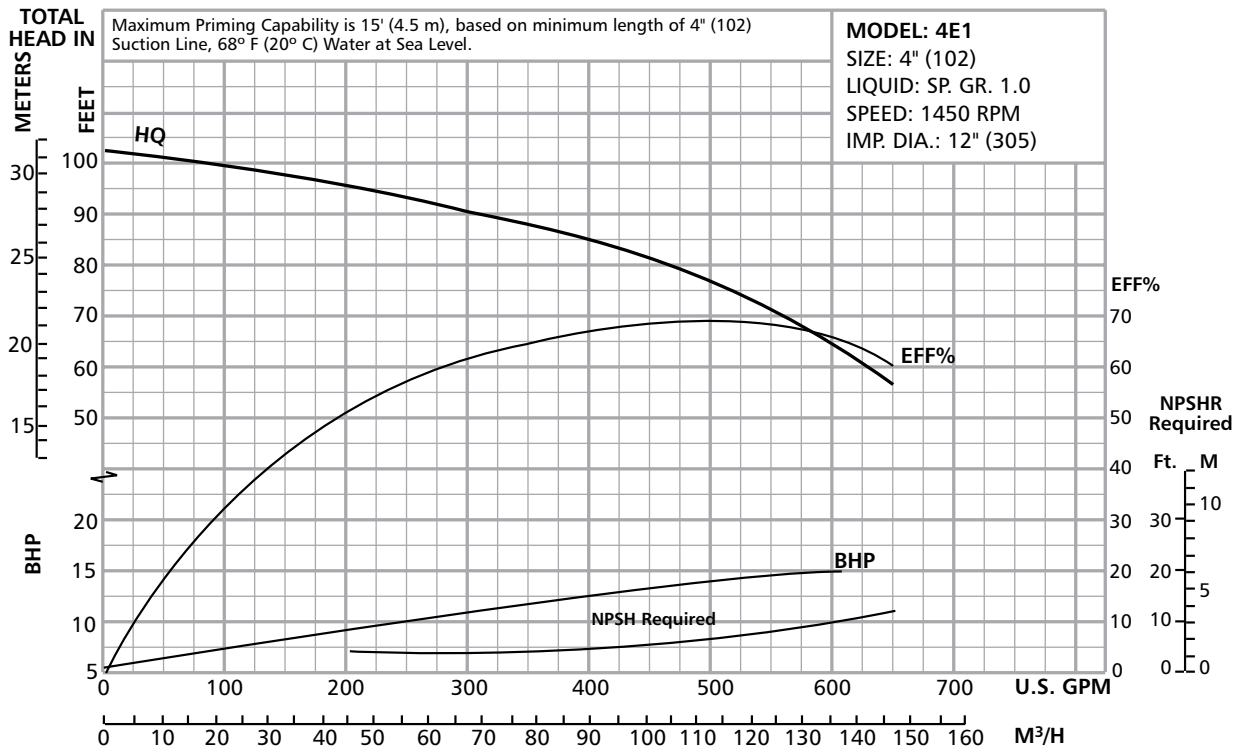

Prime Line® Performance Curves – Size 4E1, 60 Hz, 1150 RPM

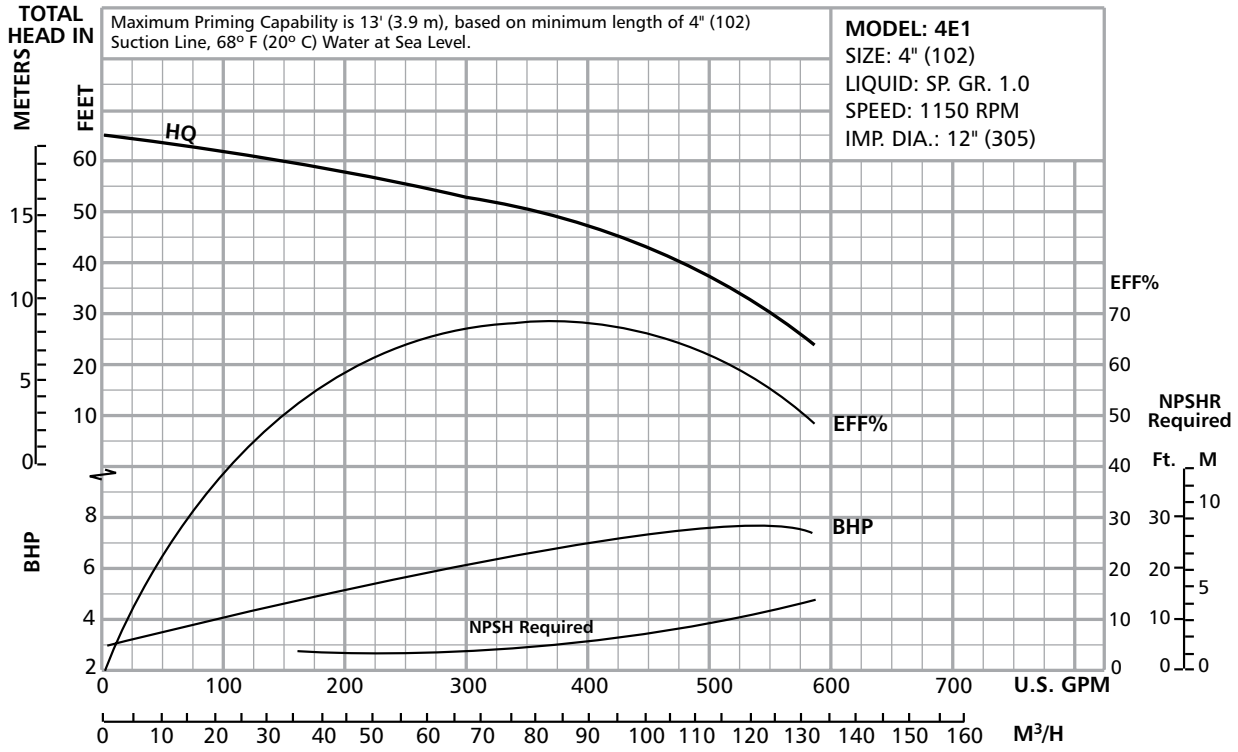

Goulds Pumps

Commercial Water

Prime Line® Performance Curves – Size 6E1, 60 Hz, 1750 RPM

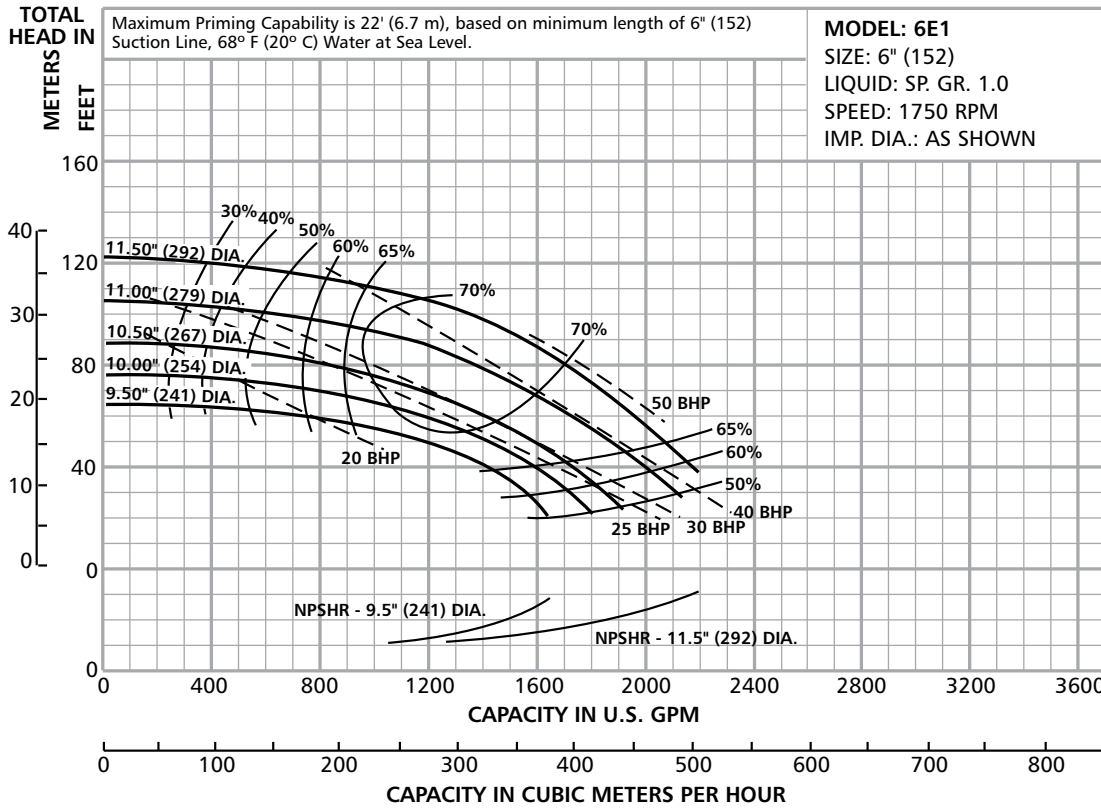

Maximum Priming Capability is:

| Ordering Code | Imp. Dia. | Max. Lift |
|---------------|-------------|-------------|
| A | 11.5" (292) | 22' (6.7 m) |
| B | 11.0" (279) | 20' (6.1 m) |
| C | 10.5" (267) | 16' (4.8 m) |
| D | 10.0" (254) | 16' (4.8 m) |
| E | 9.5" (241) | 15' (4.5 m) |

Prime Line® Performance Curves – Size 6E1, 50 Hz, 1450 RPM

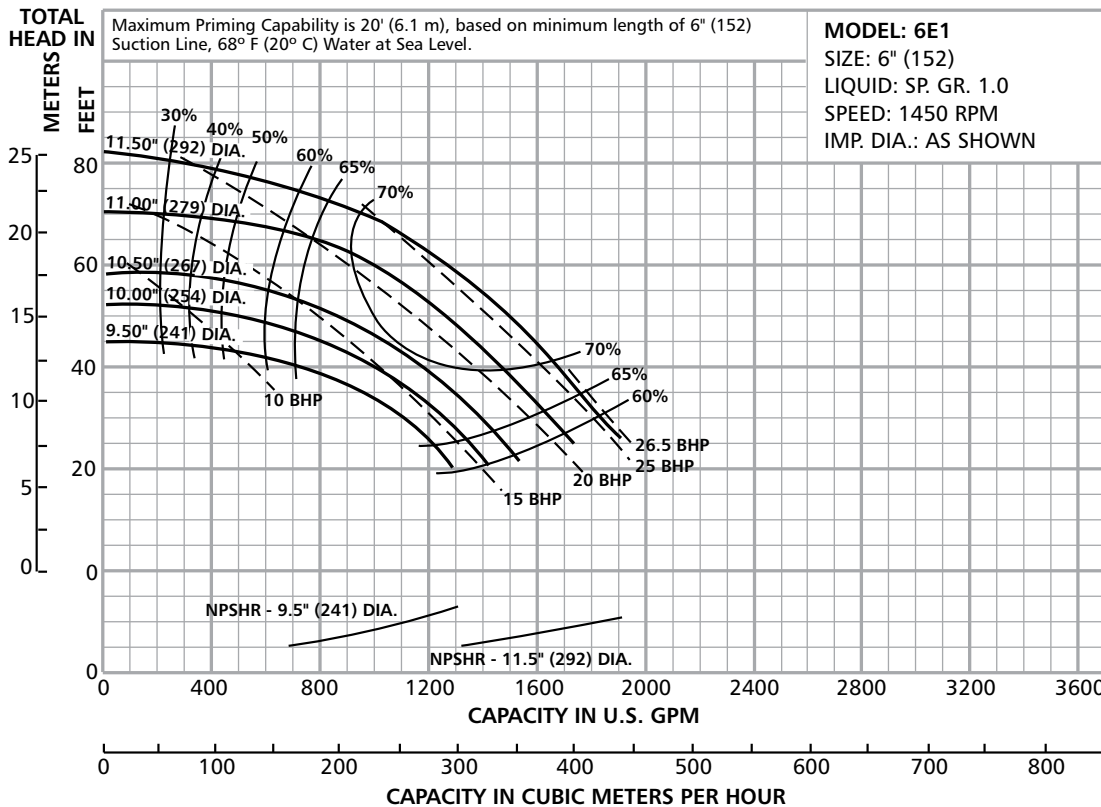

Maximum Priming Capability is:

| Ordering Code | Imp. Dia. | Max. Lift |
|---------------|-------------|-------------|
| A | 11.5" (292) | 20' (6.1 m) |
| B | 11.0" (279) | 17' (5.2 m) |
| C | 10.5" (267) | 14' (4.2 m) |
| D | 10.0" (254) | 14' (4.2 m) |
| E | 9.5" (241) | 13' (3.9 m) |

Prime Line® Performance Curves – Size 6E1, 60 Hz, 1150 RPM

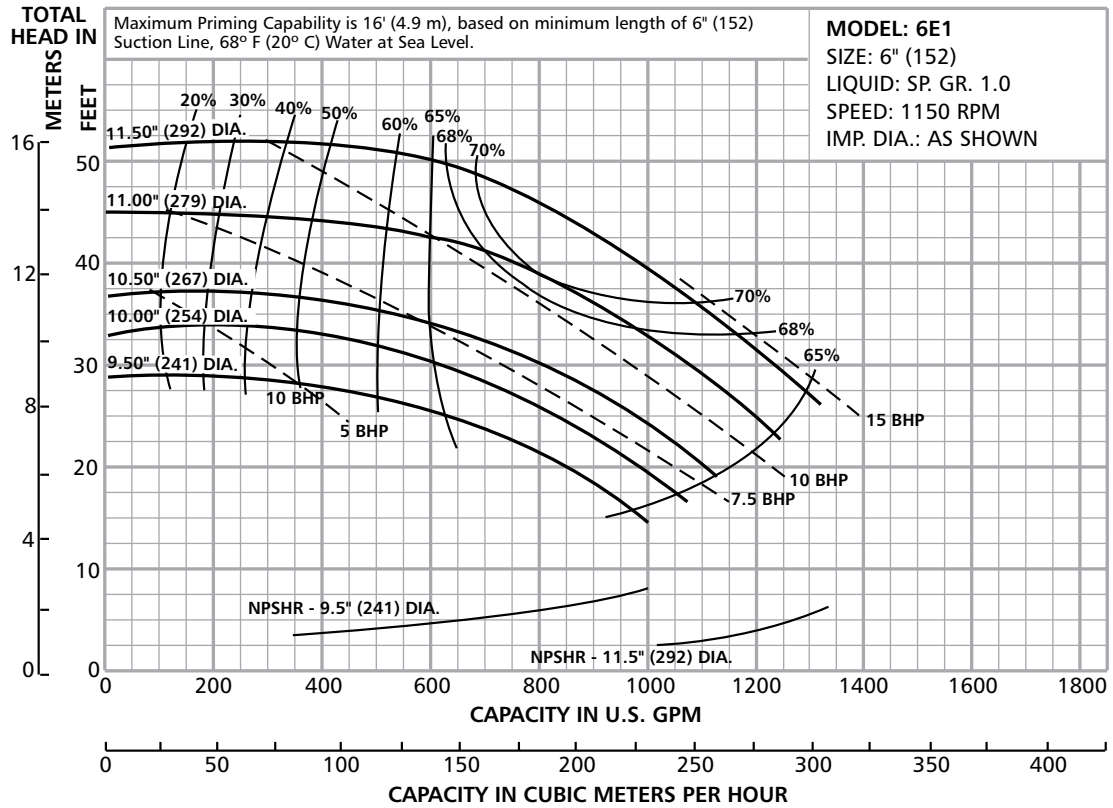

Maximum Priming Capability is:

| Ordering Code | Imp. Dia. | Max. Lift |
|---------------|-------------|-------------|
| A | 11.5" (292) | 16' (4.9 m) |
| B | 11.0" (279) | 13' (3.9 m) |
| C | 10.5" (267) | 11' (3.3 m) |
| D | 10.0" (254) | 11' (3.3 m) |
| E | 9.5" (241) | 10' (3.0 m) |

Goulds Pumps

Commercial Water

Prime Line® Performance Curves – Size 6E2, 60 Hz, 1750 RPM

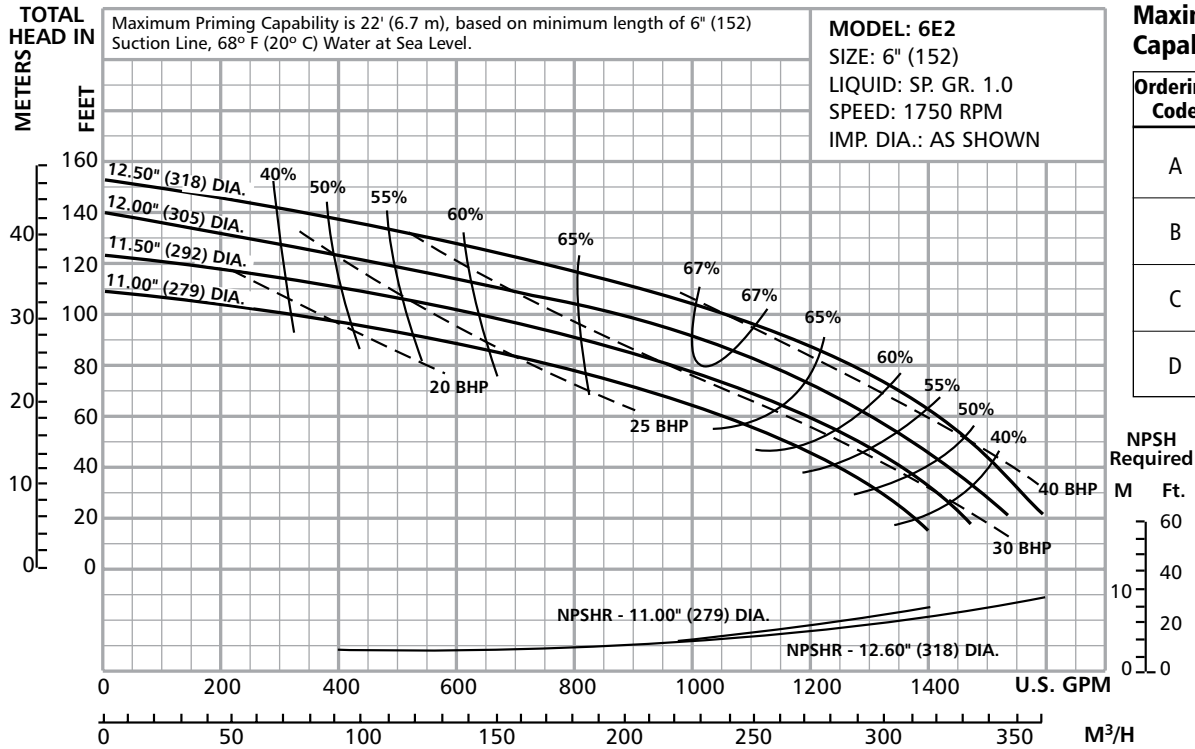

Maximum Priming Capability is:

| Ordering Code | Imp. Dia. | Max. Lift |
|---------------|-------------|-------------|
| A | 12.5" (318) | 22' (6.7 m) |
| B | 12.0" (305) | 18' (5.5 m) |
| C | 11.5" (292) | 14' (4.3 m) |
| D | 11.0" (279) | 10' (3.0 m) |

Prime Line® Performance Curves – Size 6E2, 50 Hz, 1450 RPM

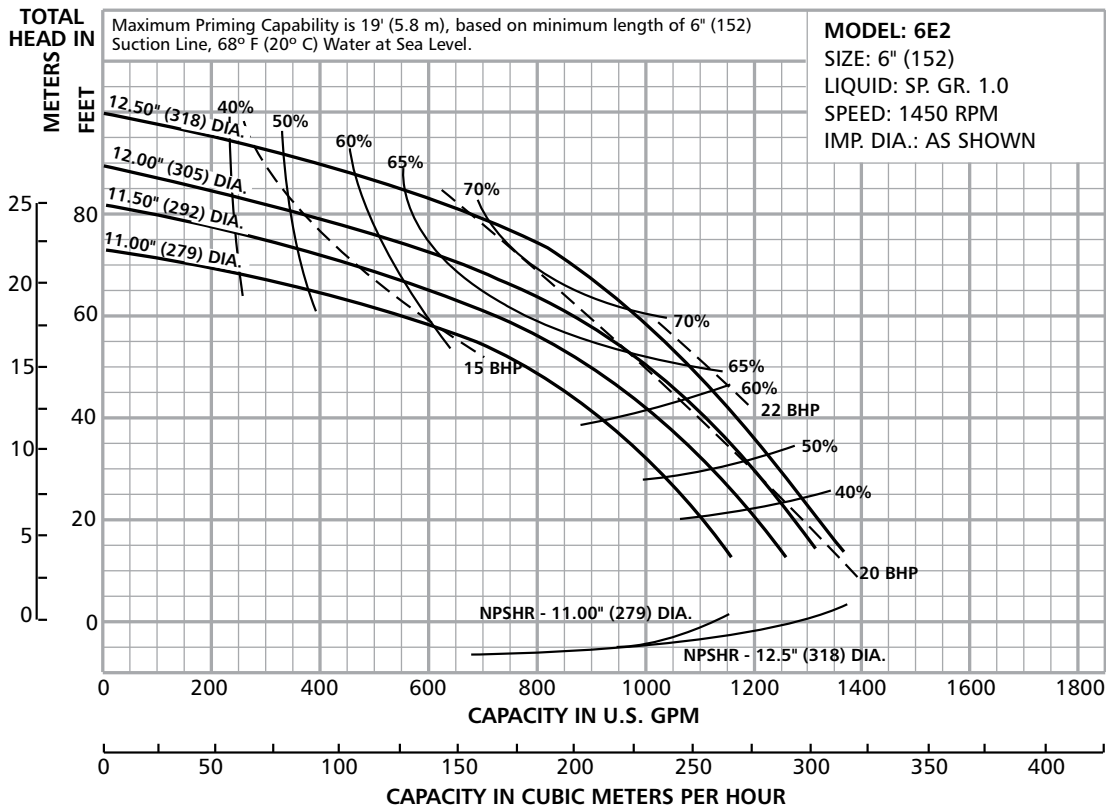

Maximum Priming Capability is:

| Ordering Code | Imp. Dia. | Max. Lift |
|---------------|-------------|-------------|
| A | 12.5" (318) | 19' (5.8 m) |
| B | 12.0" (305) | 15' (4.5 m) |
| C | 11.5" (292) | 12' (3.6 m) |
| D | 11.0" (279) | 9' (2.7 m) |

Prime Line® Performance Curves – Size 6E2, 60 Hz, 1150 RPM

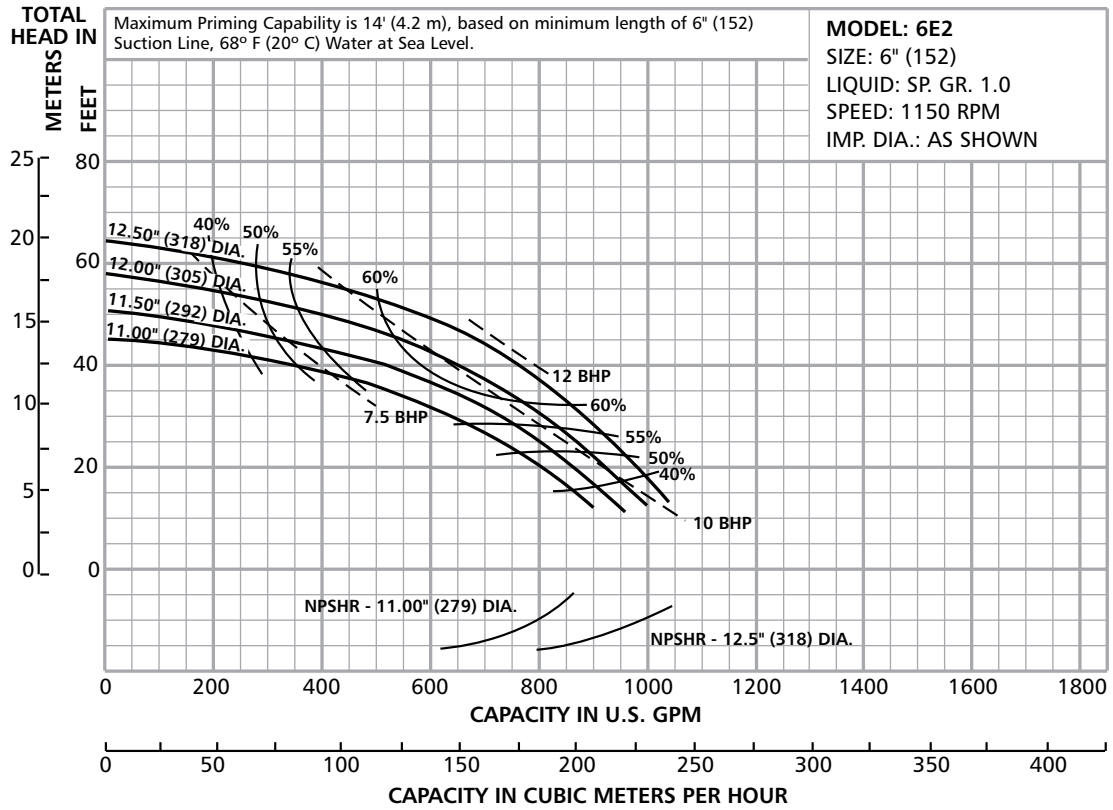

Maximum Priming Capability is:

| Ordering Code | Imp. Dia. | Max. Lift |
|---------------|-------------|-------------|
| A | 12.5" (318) | 14' (4.2 m) |
| B | 12.0" (305) | 10' (3.0 m) |
| C | 11.5" (292) | 9' (2.7 m) |
| D | 11.0" (279) | 8' (2.4 m) |

Goulds Pumps

Commercial Water

Prime Line® Dimensions — 2P – 4P Pump End

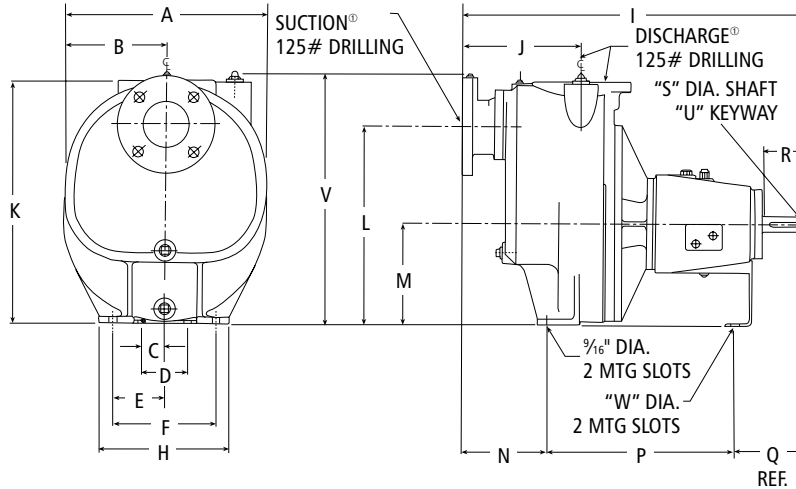

Pump End

| Model | Suction ^① | Discharge ^① | A | B | C | D | E | F | H | I | J | K | L | M | N | P | Q | R | S | U | V | W |
|-------|--------------------------|--------------------------|--------------|-------------|-----------|-----------|------------|------------|-------------|--------------|--|-------------|--------------|-------------|---|--|-------------|-------------|------------|-------------------------------|---|-----------|
| 2P1 | 2" NPT Female (51) | 2" NPT Female (51) | 12¼ (311) | 6⅞ (156) | 1 | 2 (51) | 4 (102) | 8 (203) | 10 (254) | 23½ (597) | 8 ¹⁵ / ₁₆ (227) | 17 (432) | 13⅞ (253) | 6¼ (159) | 5⅝ (143) | 11 ⁷ / ₁₆ (292) | 6⅜ (165) | 3 (76) | 1⅝ (29) | ¼ x ⅛ (6 x 3) | 17 ¹⁷ / ₁₆ (446) | ½ (13) |
| 2P2 | | | | | | | | | | | | | | | | | | | | | | |
| 2P3 | | | | | | | | | | | | | | | | | | | | | | |
| 2P4 | | | | | | | | | | | | | | | | | | | | | | |
| 3P1 | 3" (76) | 3" (76) | 15½ (391) | 7¾ (197) | 1 (25) | 2 (51) | 4 (102) | 8 (203) | 10 (254) | 24¼ (616) | 9⅞ (232) | 19 (483) | 15½ (394) | 8 (203) | 6 ⁶ / ₁₆ (167) | 11 ⁵ / ₁₆ (286) | 7⅞ (191) | 3⅞ (101) | 1⅝ (41) | ⅜ x ⅜ ₁₆ (10x5) | 19 ¹¹ / ₁₆ (500) | ½ (13) |
| 3P2 | | | | | | | | | | | | | | | | | | | | | | |
| 3P3 | | | | | | | | | | | | | | | | | | | | | | |
| 3P4 | | | | | | | | | | | | | | | | | | | | | | |
| 4P1 | 4" (102) | 4" (102) | 19¼ (489) | 9⅝ (245) | 1 | 2 | 6¼ | 12½ | 15 | 35⅝ | 11 ¹¹ / ₁₆ | 23½ | 18 | 10 | 8 ⁸ / ₁₆ | 19½ | 7⅞ | 3⅞ | 1⅝ | ⅜ x ⅜ ₁₆ | 24 ¹ / ₁₆ | ½ |
| 4P2 | | | | | | | (159) | (318) | (381) | (902) | (294) | (597) | (457) | (254) | (217) | (495) | (191) | (101) | (41) | (10x5) | (611) | |

① 125# drilling except 2PL series (2" NPT female)

All dimensions are in inches and millimeters (mm). Do not use for construction purposes.

Prime Line® Dimensions — 2P – 4P Frame Mounted

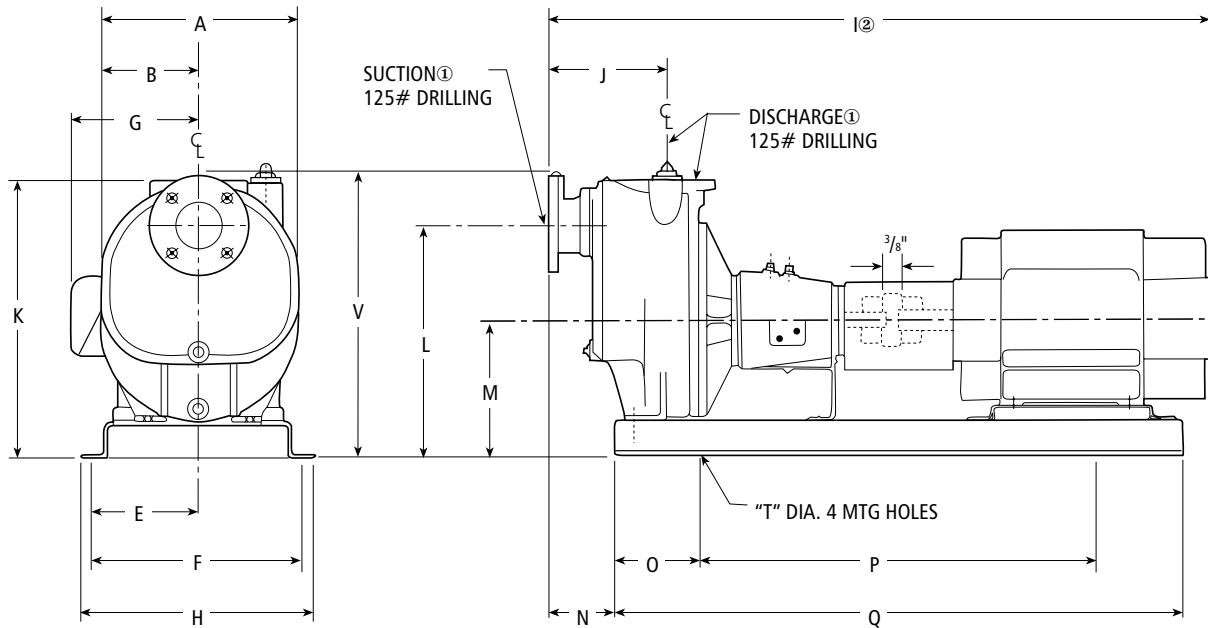

Pump, Base, Coupling and Guard

| Model | Frame | Suction ① | Discharge ① | A | B | E | F | Open G | Encl. G | H | I ② | J | K | L | M | N | O | P | Q | T | V |
|--------------------------|-----------|--------------------------|--------------------------|--------------|-------------|-------------|-------------|-----------|-------------|--------------|------------|-------------|--------------|--------------|--------------|-------------|-------------|--------------|--------------|-------------|--------------|
| 2P1 2P2 2P3 2P4 | 143T | 2" NPT Female (51) | 2" NPT Female (51) | 12¼ (311) | 6⅝ (156) | 7½ (191) | 15 (381) | — | 6½ (165) | 17 (432) | 38¾ (972) | 8⅛ (227) | 19½ (495) | 16⅝ (416) | 8¾ (222) | 4⅞ (118) | 26 (660) | 42 (1067) | | | 20⅞ (509) |
| | 145T | | | | | | | 6⅝ (160) | 39 (991) | | | | | | | | | | | | |
| | 182T | | | | | | | 7⅞ (195) | 42¾ (1076) | | | | | | | | | | | | |
| | 184T | | | | | | | 8⅞ (227) | 46½ (1181) | | | | | | | | | | | | |
| | 213T | | | | | | | — | 6½ (165) | | 38 (965) | | | | | | | | | | |
| | 215T | | | | | | | 6⅝ (160) | 38⅞ (987) | | | | | | | | | | | | |
| 3P1 3P2 | 145T | 3" (76) | 3" (76) | 15½ (391) | 7¾ (197) | 9½ (241) | 19 (483) | — | 6½ (165) | 20½ (521) | 47¾ (1213) | 9⅞ (232) | 21½ (546) | 18 (457) | 10½ (267) | 4¾ (121) | 8 (203) | 32 (813) | 48 (1219) | 11⅞ (18) | 22⅞ (564) |
| | 182T | | | | | | | 6⅝ (160) | 48⅞ (1229) | | | | | | | | | | | | |
| | 184T | | | | | | | 7⅞ (195) | 51¾ (1315) | | | | | | | | | | | | |
| | 213T | | | | | | | 8⅞ (227) | 55 (1397) | | | | | | | | | | | | |
| | 215T | | | | | | | 11½ (292) | 11⅞ (302) | | 60¼ (1530) | | | | | | | | | | |
| | 254T | | | | | | | 13⅞ (344) | 14⅞ (357) | | 61¼ (1556) | | | | | | | | | | |
| 3P3 3P4 | 145T | 4" (102) | 4" (102) | 19¼ (489) | 9⅝ (245) | 7⅞ (195) | 8⅞ (227) | — | 6½ (165) | 54½ (1384) | 11⅞ (294) | 26 (660) | 20½ (521) | 12⅞ (318) | 7½ (191) | 32 (813) | 48 (1219) | 40 (1016) | 56 (1422) | 26⅞ (675) | |
| | 182T | | | | | | | 6⅝ (160) | 58¾ (1492) | | | | | | | | | | | | |
| | 184T | | | | | | | 11½ (292) | 11⅞ (302) | | | | | | | | | | | | 60¼ (1530) |
| | 213T | | | | | | | 13⅞ (344) | 14⅞ (357) | | | | | | | | | | | | 61¼ (1556) |
| | 215T | | | | | | | 7⅞ (195) | 8⅞ (227) | | | | | | | | | | | | 54½ (1384) |
| | 254T | | | | | | | 8⅞ (227) | 58¾ (1492) | | | | | | | | | | | | |
| 4P1 4P2 | 213T | 4" (102) | 4" (102) | 19¼ (489) | 9⅝ (245) | 7⅞ (195) | 8⅞ (227) | — | 6½ (165) | 54½ (1384) | 11⅞ (294) | 26 (660) | 20½ (521) | 12⅞ (318) | 7½ (191) | 32 (813) | 48 (1219) | 40 (1016) | 56 (1422) | 26⅞ (675) | |
| | 215T | | | | | | | 6⅝ (160) | 58¾ (1492) | | | | | | | | | | | | |
| | 254T | | | | | | | 11½ (292) | 11⅞ (302) | | | | | | | | | | | | 60¼ (1530) |
| 256T | 13⅞ (344) | 14⅞ (357) | 61¼ (1556) | | | | | | | | | | | | | | | | | | |

① 125# drilling except 2PL series (2" NPT female).

② Actual dimension may vary depending on motor.

All dimensions are in inches and millimeters (mm). Do not use for construction.

Goulds Pumps

Commercial Water

Prime Line® Dimensions — 2P – 4P Close Coupled

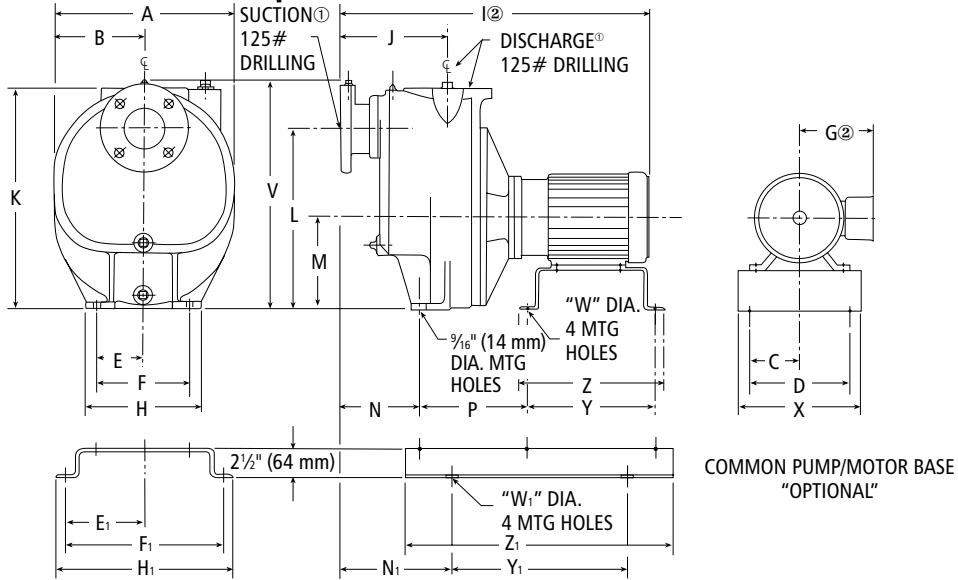

Close Coupled

| Model | Frame | Suct. ① | Disch. ① | A | B | C | D | E | F | G | H | I ② | J | K | L | M | N | P | V | W | X | Y | Z | With Pump – Motor Base | | | | | | | | | | | | | | | | | | | | | | | |
|--------------------------|-------|--------------------------|--------------------------|-----------------|----------------|--------|-------|-------|--------|-------|----|---------|---------|--------|--------|-------|--------|---------|----------------|---------------|--------|--------|--------|------------------------|----------------|----------------|----------------|----------------|----------------|----------------|---------|----------|---------------|---------------|---------------|---------|---------|---------------|---------|---------|--------|---------|-----|-----|---------|----|----|
| | | | | | | | | | | | | | | | | | | | | | | | | E ₁ | F ₁ | H ₁ | N ₁ | W ₁ | Y ₁ | Z ₁ | | | | | | | | | | | | | | | | | |
| 2P1 2P2 2P3 2P4 | 143JM | 2" NPT Female (51) | 2" NPT Female (51) | 12 1/4 (311) | 6 1/8 (156) | 4 1/16 | 9 1/8 | 4 | 8 | 6 1/8 | 10 | 23 3/4 | 8 5/16 | 17 | 13 3/8 | 6 1/4 | 5 3/8 | 16 5/8 | 17 1/8 | 7/16 | 9 1/2 | 11 | 12 3/8 | 6 5/8 | 13 3/4 | 14 3/4 | 8 5/8 | 9 1/16 | 15 | 23 | | | | | | | | | | | | | | | | | |
| | 145JM | | | | | 3 | 6 | | | | | | | | | | | | | | | | | | | | | | | | 27 5/16 | 9 5/16 | 7/16 x 1 1/16 | 10 1/2 | 11 1/2 | 168 | 337 | 375 | 219 | 14 | 381 | 584 | | | | | |
| | 182JM | | | | | 3 | 6 | | | | | | | | | | | | | | | | | | | | | | | | 27 5/16 | 9 5/16 | 7/16 x 1 1/16 | 10 1/2 | 11 1/2 | 168 | 337 | 375 | 219 | 14 | 381 | 584 | | | | | |
| | 184JM | | | | | 3 | 6 | | | | | | | | | | | | | | | | | | | | | | | | 27 5/16 | 9 5/16 | 7/16 x 1 1/16 | 10 1/2 | 11 1/2 | 168 | 337 | 375 | 219 | 14 | 381 | 584 | | | | | |
| | 213JP | | | | | 5 1/2 | 10 | | | | | | | | | | | | | | | | | | | | | | | | 37 7/8 | 17 1/8 | 11 3/8 | 5 7/8 | 16 5/8 | 17 1/8 | 7/16 | 9 1/2 | 140 | 187 | 194 | 387 | 425 | 270 | 18 1/16 | 18 | 30 |
| | 215JP | | | | | 5 1/2 | 10 | | | | | | | | | | | | | | | | | | | | | | | | 37 7/8 | 17 1/8 | 11 3/8 | 5 7/8 | 16 5/8 | 17 1/8 | 7/16 | 9 1/2 | 140 | 187 | 194 | 387 | 425 | 270 | 18 1/16 | 18 | 30 |
| 3P1 3P2 3P3 3P4 | 143JM | 3" (76) | 3" (76) | 15 1/2 (391) | 7 3/4 (197) | 4 1/16 | 9 1/8 | 4 | 8 | 6 1/8 | 10 | 24 1/16 | 9 1/8 | 19 | 15 1/2 | 8 | 6 5/16 | 19 1/16 | 14 3/8 | 7/16 x 1 1/16 | 11 3/4 | 11 1/2 | 12 7/8 | 7 1/8 | 15 1/4 | 16 3/4 | 11 1/16 | 9 1/16 | 15 | 23 | | | | | | | | | | | | | | | | | |
| | 145JM | | | | | | | | | | | | | | | | | | | | | | | | | | | | | | 3 1/2 | 6 1/2 | 28 1/8 | 9 5/16 | 7/16 x 1 1/16 | 10 1/2 | 11 | 12 3/8 | 168 | 337 | 375 | 243 | 14 | 381 | 584 | | |
| | 182JM | | | | | | | | | | | | | | | | | | | | | | | | | | | | | | 3 1/2 | 6 1/2 | 28 1/8 | 9 5/16 | 7/16 x 1 1/16 | 10 1/2 | 11 | 12 3/8 | 168 | 337 | 375 | 243 | 14 | 381 | 584 | | |
| | 184JM | | | | | | | | | | | | | | | | | | | | | | | | | | | | | | 3 1/2 | 6 1/2 | 28 1/8 | 9 5/16 | 7/16 x 1 1/16 | 10 1/2 | 11 | 12 3/8 | 168 | 337 | 375 | 243 | 14 | 381 | 584 | | |
| | 213JP | | | | | | | | | | | | | | | | | | | | | | | | | | | | | | 5 1/2 | 11 | 34 1/2 | 18 1/2 | 11 3/8 | 6 1/4 | 14 3/8 | 7/16 x 1 1/16 | 11 3/4 | 11 1/2 | 12 7/8 | 194 | 387 | 425 | 294 | 18 | 30 |
| | 215JP | | | | | | | | | | | | | | | | | | | | | | | | | | | | | | 5 1/2 | 11 | 34 1/2 | 18 1/2 | 11 3/8 | 6 1/4 | 14 3/8 | 7/16 x 1 1/16 | 11 3/4 | 11 1/2 | 12 7/8 | 194 | 387 | 425 | 294 | 18 | 30 |
| | 254JP | | | | | | | | | | | | | | | | | | | | | | | | | | | | | | 5 1/2 | 11 | 39 5/8 | 19 1/2 | 12 1/8 | 8 1/8 | 19 1/16 | 13 1/2 | 15 1/16 | 17 5/16 | 194 | 387 | 425 | 294 | 18 | 30 | |
| | 256JP | | | | | | | | | | | | | | | | | | | | | | | | | | | | | | 5 1/2 | 11 | 39 5/8 | 19 1/2 | 12 1/8 | 8 1/8 | 19 1/16 | 13 1/2 | 15 1/16 | 17 5/16 | 194 | 387 | 425 | 294 | 18 | 30 | |
| | 284JP | | | | | | | | | | | | | | | | | | | | | | | | | | | | | | 5 1/2 | 11 | 41 3/8 | 20 1/2 | 12 1/8 | 8 1/8 | 19 1/16 | 13 1/2 | 15 1/16 | 17 5/16 | 194 | 387 | 425 | 294 | 18 | 30 | |
| | 286JP | | | | | | | | | | | | | | | | | | | | | | | | | | | | | | 5 1/2 | 11 | 41 3/8 | 20 1/2 | 12 1/8 | 8 1/8 | 19 1/16 | 13 1/2 | 15 1/16 | 17 5/16 | 194 | 387 | 425 | 294 | 18 | 30 | |
| 4P1 4P2 | 213JP | 4" (102) | 4" (102) | 19 1/4 (489) | 9 5/8 (245) | 4 1/16 | 9 1/8 | 6 1/8 | 12 1/2 | 9 1/8 | 15 | 37 5/16 | 11 1/16 | 23 1/2 | 18 | 10 | 8 3/16 | 24 1/16 | 9 1/8 x 1 1/16 | 11 3/4 | 11 1/2 | 12 7/8 | 9 3/8 | 18 3/4 | 20 1/4 | 11 1/16 | 13 3/16 | 21 | 33 | | | | | | | | | | | | | | | | | | |
| | 215JP | | | | | | | | | | | | | | | | | | | | | | | | | | | | | 3 1/2 | 6 1/2 | 38 13/16 | 9 5/16 | 7/16 x 1 1/16 | 10 1/2 | 11 | 12 3/8 | 168 | 337 | 375 | 294 | 18 1/16 | 18 | 30 | | | |
| | 254JP | | | | | | | | | | | | | | | | | | | | | | | | | | | | | 3 1/2 | 6 1/2 | 41 13/16 | 20 1/2 | 12 1/8 | 8 1/8 | 19 1/16 | 13 1/2 | 15 1/16 | 17 5/16 | 194 | 387 | 425 | 294 | 18 | 30 | | |
| | 256JP | | | | | | | | | | | | | | | | | | | | | | | | | | | | | 3 1/2 | 6 1/2 | 41 13/16 | 20 1/2 | 12 1/8 | 8 1/8 | 19 1/16 | 13 1/2 | 15 1/16 | 17 5/16 | 194 | 387 | 425 | 294 | 18 | 30 | | |

① 125# drilling except 2PL series (2" NPT female).

② Actual dimension may vary depending on motor.

All dimensions are in inches and millimeters (mm). Do not use for construction purposes.

Prime Line® Dimensions — 4E – 6E

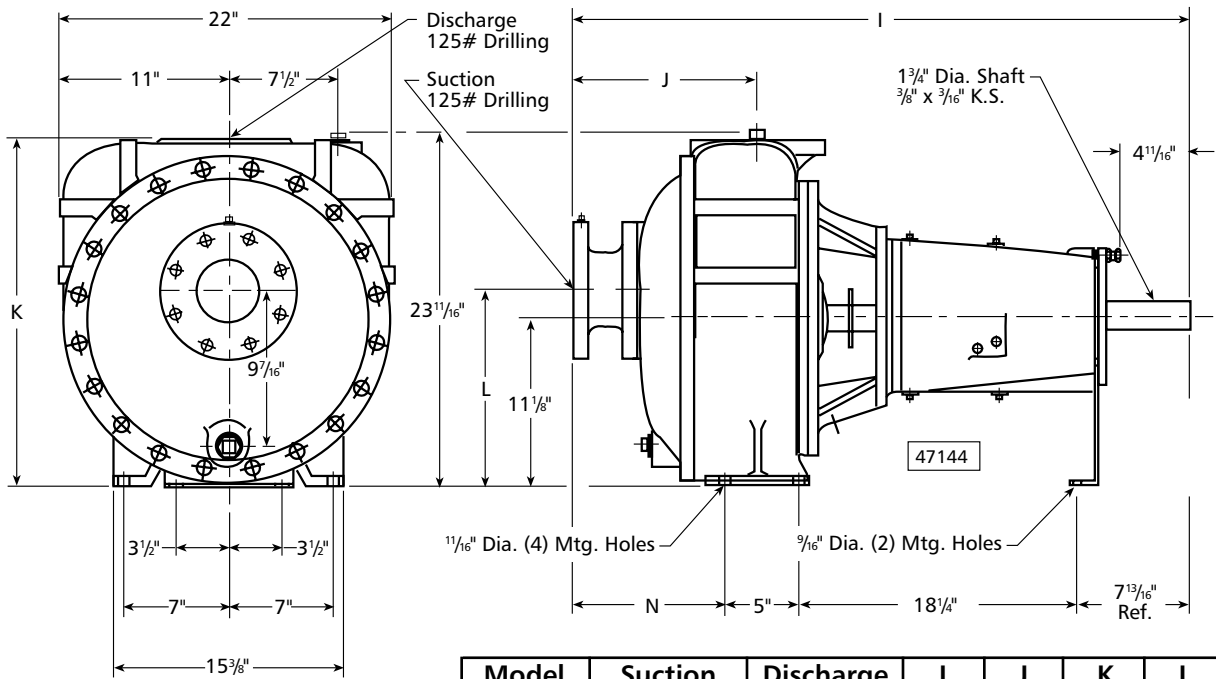

| Model | Suction | Discharge | I | J | K | L | N |
|-------|---------|-----------|---------------------------------|---------------------------------|--------------------------------|--------------------------------|---------------------------------|
| 4E | 4 | 4 | 40 ⁷ / ₈ | 12 ⁵ / ₁₆ | 23 | 13 | 9 ¹³ / ₁₆ |
| 6E | 6 | 6 | 44 ⁵ / ₁₆ | 15 ³ / ₄ | 24 ¹ / ₂ | 11 ³ / ₈ | 13 ¹ / ₄ |

Pump, Base, Coupling and Motor

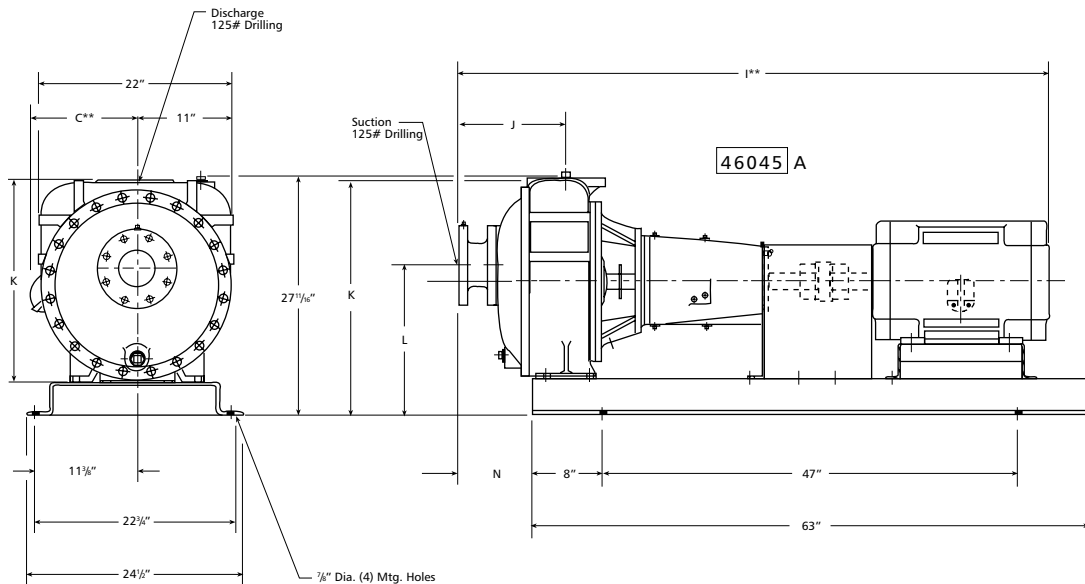

| Model | Suction | Discharge | Frame | C** | I** | J | K | L | N |
|-------|---------|-----------|-------|---------------------------------|----------------------------------|---------------------------------|--------------------------------|--------------------------------|--------------------------------|
| 4E | 4 | 4 | 254T | 8 ¹⁵ / ₁₆ | 63 ³ / ₁₆ | 12 ⁵ / ₁₆ | 27 | 17 | 8 ⁵ / ₁₆ |
| | | | 256T | | 63 ¹⁵ / ₁₆ | | | | |
| | | | 284T | | 65 ⁷ / ₁₆ | | | | |
| | | | 286T | | 66 ¹⁵ / ₁₆ | | | | |
| 6E | 6 | 6 | 256T | 8 ¹⁵ / ₁₆ | 67 ³ / ₈ | 15 ³ / ₄ | 28 ¹ / ₂ | 15 ³ / ₈ | 11 ³ / ₄ |
| | | | 284T | | 68 ⁷ / ₈ | | | | |
| | | | 286T | | 70 ³ / ₈ | | | | |
| | | | 324T | | 71 ⁹ / ₁₆ | | | | |
| | | | 326T | | 73 ¹ / ₁₆ | | | | |

Goulds Pumps

Commercial Water

Prime Line® Specifications — 2P – 4P

Mechanical Data

| | 2P1 | 2P2 | 2P3 | 2P4 | 3P1 | 3P2 | 3P3 | 3P4 | 4P1 | 4P2 |
|---|----------------------------|--------------|-----------|----------|------------------------------------|--------------|--------------|-----------|-----------------|-----------|
| Suction and discharge port sizes, inches (mm) | 2 (51) NPT | | | | 3 (76) Flanged | | | | 4 (102) Flanged | |
| Flanged, flat face | Female threaded connection | | | | 125 PSI (8.79 kg/cm ²) | | | | | |
| Minimum casing thickness, inches (mm) | 3/8 (10) | | | | | | | | | |
| Maximum working pressure | 85 PSI | | | | 115 PSI | | | | 60 PSI | |
| Maximum hydrostatic test pressure (refer to note #4) | 130 PSI | | | | 170 PSI | | | | 90 PSI | |
| Maximum diameter solids (spherical), inches (mm) | 1/2 (13) | 7/16 (11) | 7/16 (11) | 5/16 (8) | 7/16 (11) | 9/16 (14) | 5/8 (16) | 1/2 (13) | 9/16 (14) | 9/16 (14) |
| Shaft Diameter | | | | | | | | | | |
| a) At impeller (nominal), inches (mm) | 7/8 (22) | | | | 1 1/4 (32) | | | | | |
| b) At mechanical seal, inches (mm) | 1 1/4 (32) | | | | 1 5/8 (41) | | | | | |
| c) Between bearings, inches (mm) | 1 5/8 (41) | | | | 2 5/16 (59) | | | | | |
| d) At coupling, inches (mm) | 1 1/8 (29) | | | | 1 5/8 (41) | | | | | |
| Maximum shaft deflection at shaft seal faces, inches (mm) | Does not exceed .002 (.05) | | | | | | | | | |
| Bearing Housing | | | | | | | | | | |
| a) Front radial bearing | 6207 | | | | 6309 | | | | | |
| b) Rear thrust bearing | 6307 | | | | 5310 | | | | | |
| c) Bearing centers, inches (mm) | 4 7/16 (110) | | | | 6 7/8 (175) | | | | | |
| Minimum distance required to remove bearing housing assembly with impeller, stuffing box/seal plate and bracket (back pull-out) (refer to note #1), inches (mm) | 4 (102) | | | | | | | | 5 (127) | |
| Maximum temperature of liquid pumped for normal seal operation | 200°F (93°C) | | | | | | | | | |
| Speed range, RPM | 1450 to 2150 | 2400 to 3450 | | | 1450 to 2150 | 2400 to 3450 | 1750 to 3450 | | 1150 to 2400 | |
| Static priming lift, with full diameter impeller at maximum allowable operating speed and with suction check valve (refer to note #2) | 25 feet (7.6 m) | | | | | | | | | |
| Minimum B ₁₀ life hours (refer to note #3) | 20,000 hrs + | | | | | | | | | |
| Weight, pump end only, lbs. (kg) | 176 (80) | 169 (76) | 176 (80) | 176 (80) | 250 (113) | 235 (106) | 294 (133) | 294 (133) | 410 (186) | 400 (182) |
| Weight, back pull-out section (bearing housing, stuffing box/seal plate impeller, seal assembly, shaft, bearings, etc.), lbs. (kg) | 75 (34) | 72 (32) | 75 (34) | 75 (34) | 100 (45) | 90 (41) | 160 (73) | 160 (73) | 185 (84) | 175 (80) |
| Shipping weight, PEO, lbs. (kg) | 190 (86) | 185 (84) | 190 (86) | 190 (86) | 275 (125) | 260 (118) | 310 (141) | 310 (141) | 425 (193) | 415 (188) |

NOTES:

- Distance shown required for removal of complete back pull-out assembly straight out of pump casing.
- Based on nominal pipe size with 5 feet (1.5 m) horizontal length, zero discharge head and 68°F (20°C) water temperature at sea level.
- Based on an operating point at 50% of BEP capacity.
- Without check valve or check valve partially open.

Prime Line® Specifications — 4E1, 6E1, 6E2

Mechanical Data

| | 4E1 | 6E1 | 6E2 |
|--|----------------------|--------------|--------------|
| Suction and discharge port sizes, inches | 4" x 4" | 6" x 6" | 6" x 6" |
| Flanged, flat face, PSI | 125 | 125 | 125 |
| Minimum casing thickness, inches | ½ | ½ | ½ |
| Maximum working pressure, PSI | 125 | 65 | 145 |
| Maximum hydrostatic test pressure (refer to note #4) | 185 | 95 | 215 |
| Type of impeller | Enclosed | Open | Enclosed |
| Maximum diameter solids (spherical), inches | ½ | 1 | 1 |
| Shaft Diameter | | | |
| a) At impeller (nominal), inches | | 1¾ | |
| b) At mechanical seal, inches | | 1¾ | |
| c) Between bearings, inches | | 3 | |
| d) At coupling, inches | | 1¾ | |
| Maximum shaft deflection at shaft seal faces, inches | Does not exceed .002 | | |
| Bearing Housing | | | |
| a) Front radial bearing, single row | | #313 | |
| b) Rear thrust bearing, single row | | #313 | |
| c) Bearing centers, inches | | 10.040 | |
| Minimum distance required to remove bearing housing assembly with impeller, stuffing box/seal plate and bracket (back pull-out) (refer to note #1), inches | | 5½ | |
| Maximum temperature of liquid pumped for normal seal operation | 200°F (93°C) | | |
| Speed range, RPM | 1150 to 2400 | 1150 to 2000 | 1150 to 2600 |
| Static priming lift, with full diameter impeller at maximum allowable operating speed and with suction check valve (refer to note #2) | 25 feet | 22 feet | 22 feet |
| Oil capacity for oil lube bearings (bearing housing) | Approx. 52 fl. oz. | | |
| Minimum L ₁₀ life, hours (refer to note #3) | 24,000 | | |
| Weight, pump end only, lbs. | 550 | 610 | 620 |
| Weight, back pull-out section (bearing housing, stuffing box/seal plate impeller, seal assembly, shaft, bearings, etc.), lbs. | 400 | 460 | 470 |
| Shipping weight, PEO, lbs. | 580 | 640 | 650 |

NOTES:

1. Distance shown required for removal of complete back pull-out assembly straight out of pump casing.
2. Based on nominal pipe size with 5 feet (1.5 m) horizontal length, zero discharge head and 68°F (20°C) water temperature at sea level.
3. Based on an operating point at 50% of BEP capacity.
4. Without check valve or check valve partially open.

ITT

2881 East Bayard Street, Seneca Falls, NY 13148

Phone: (315) 568-7123 • Fax: (315) 568-7973

www.goulds.com

Goulds Pumps is a registered trademark of ITT Corporation. ITT, the Engineered Blocks Symbol and Engineered for Life are registered trademarks of ITT Manufacturing Enterprises, Inc.

Copyright © 2009 ITT Corporation GPrimeLine August, 2009
SPECIFICATIONS ARE SUBJECT TO CHANGE WITHOUT NOTICE.

Printed in U.S.A.



Engineered for life