



Close-Coupled Self-Priming

MODEL

3656 SP

APPLICATIONS

Specifically designed for following uses:

- Irrigation
- Water transfer
- Lawn sprinkling
- Air conditioning

SPECIFICATIONS

Pump

- Capacities: to 145 GPM
- Heads: to 135 feet
- Reprime capabilities: to 25' suction lift.
- Pipe connections:
Suction – 2" NPT Discharge – 2" NPT
- Temperature: 160°F, 71°C maximum
- Rotation: right hand ie; clockwise when viewed from motor end.

Motor

- NEMA standard, JM shaft, open drip proof only.
- 60 Hz, 3500 RPM
- Single phase: 3 HP, 115/230 V; 5 HP, 230 V only.
- Three phase: 3 and 5 HP, 200-230/430 V.
- Overload protection must be provided. Contactor with overload for single phase and starter with heaters for three phase must be ordered separately.

FEATURES

■ Self Priming Design:

Assures fast, positive priming and air handling capabilities. Once initially primed the pump will reprime automatically, should the suction be lost.

■ Impeller and Guide Vane:

Brass, replaceable, designed for maximum efficiency and repriming capabilities. Impeller is enclosed type, balanced for smooth operation, keyed to motor shaft.

■ **Casing:** Cast iron construction, back pull-out design. Tapped openings provided for vacuum gauge and casing drain.

■ **Shaft Sleeve:** 300 Series stainless steel replaceable sleeve provides motor shaft protection.

■ Mechanical Seal:

Carbon/ceramic faces, BUNA elastomers, 300 series stainless steel metal parts. Exclusive casing design prevents seal from running dry.

■ **Motor:** Close-coupled design. Ball bearings carry all radial/axial thrust loads. Designed for continuous operation. All ratings are within working limits of the motor.

■ **Corrosion-Resistant Coating:** Electro-coat paint process applied inside and out, and baked on.

Goulds Pumps is ISO 9001 Registered.

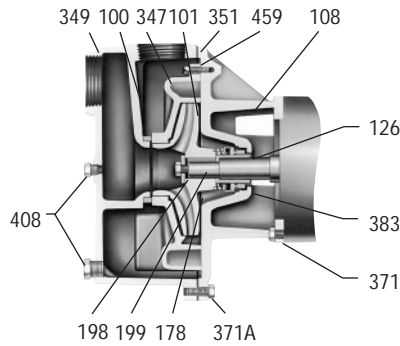

COMPONENTS

Item No.	Description	Material
100	Casing	Cast iron ASTM A48 CL20
101	Impeller	Brass ASTM B584
108	Motor adapter	Cast iron ASTM A48 CL20
126	Shaft sleeve	300 series SS
178	Impeller key	300 series SS
198	Impeller screw	300 series SS
199	Impeller washer	300 series SS
347	Guide vane	Brass ASTM B584
349	Guide vane seal	BUNA-N
351	Gasket	Composite
371	Hex head cap screw (adapter to motor)	Steel
371A	Hex head cap screw (case adapter to case)	Steel
383	Mechanical seal	John Crane Type 21; 1 1/4"
408	Pipe plug 1/2" and 3/4"	Z-Chr. plated steel
459	FIL. HD. slotted mach. screw	300 series SS

MOTOR FRAME

Motor Frame	Motor Horsepower	
	Single Phase	Three Phase
	ODP	ODP
145 JM	—	3
182 JM	3	5
184 JM	5	—

MOTOR DIMENSIONS

Frame JM	A	AB	B	BG	C	O	Wt. (lbs.)	
							1 Phase ODP	3 Phase ODP
145	7	5 7/8	6	5 3/8	6 1/8	7 1/4	—	38
182	9	8 1/8	5 3/4	5 7/8	6 3/4	9 1/4	67	55
184			6 3/4	6 3/8	7 1/4			

PERFORMANCE RATINGS (gallons per minute)

Model No.	"M" - 3656 SP			"H"-3656 SP				3656SP			
	HP			3				5			
Discharge Pressure PSI	20	30	40	20	30	40	50	30	40	50	
	(46)	(69)	(93)	(46)	(69)	(93)	(115)	(69)	(93)	(115)	
Total Suction Lift (feet)	10	120	87	—	107	92	67	26	122	115	—
	15	100	74	—	93	87	60	13	105	103	—
	20	85	55	—	78	78	57	—	86	83	—
	25	—	—	—	—	—	—	—	61	58	—

DIMENSIONS AND WEIGHTS

Pump	Suction	Discharge	K	L	M	P	R	S	W	X	Y	Z	Wt.
2 x 2 - 6	2	2	5 3/4	7 1/8	4 1/4	10	1 1/8	3/8	5 1/8	5 3/4	3 7/8	4	70

(All dimensions are in inches and weight in lbs. Do not use for construction purposes.)

